



UESTA HYBRID WATER HEATER Installation Manual

Model
| VH-150
| VH-199

Keep this manual near the water heater for future reference whenever maintenance or service is required.



⚠ Danger Water heater for other than recreational vehicle installation only

READ ALL OF THE INSTRUCTIONS THOROUGHLY BEFORE OPERATING THIS WATER HEATER.

This manual provides information on the installation, operation, and maintenance of the water heater. For proper operation and safety, it is important to follow the instructions and adhere to the safety precautions.

A licensed professional must install the water heater according to the exact instructions of the manual.

⚠ Warning If the information in these instructions is not followed exactly, fire or explosion may result causing property damage, personal injury, or death.

- Do not store or use gasoline or other flammable vapors and liquids in the vicinity of this or any other appliance.
- What to do if you smell gas
 - Do not try to light any appliance.
 - Do not touch any electrical switch; do not use any phone in your building.
 - Immediately call your gas supplier from a neighbor's phone. Follow the gas supplier's instructions.
 - If you cannot reach your gas supplier, call the fire department.
- Installation and service must be performed by a licensed professional.

Safety Information

The following safety symbols are used in this manual for user's safety. Read this manual carefully and follow all instructions to avoid property damage, fire, explosion, personal injury, or death.



Danger Indicates an imminently hazardous situation which, if not avoided, will result in severe injury or death.



Warning Indicates a potentially hazardous situation which, if not avoided, will result in injury or death.



Caution Indicates a potentially hazardous situation which, if not avoided, could result in property damage.



Danger

If you smell gas:

- Do not try to light any appliance.
- Do not touch any electrical switches or use landline phones.
- From a neighbor's phone, call your gas provider and follow their instructions.
- If you cannot reach your gas provider, call the fire department.

Do not use or store flammable products, such as gasoline, solvents, or adhesives in the same room or area as the water heater.

- Vapors from flammable liquids can explode and/or catch fire causing death or severe burns.
- Keep flammable products far away from the water heater and store them in approved containers. Keep the containers tightly closed and out of the reach of children.
- The Water heater has a main burner flame that can come on at any time and will ignite flammable vapors.
- Vapors cannot be seen and are heavier than air. Vapors travel a long way on the floor and can be carried from other rooms to the main burner flame by air currents.

Avoid using hot water over 125°F.

- Water temperature over 125°F can cause severe burns or death from scalding.
- Children, the disabled and the elderly are at highest risk of being scalded.
- Test water before bathing or showering.

Temperature	Time to Produce Serious Burn	Temperature	Time to Produce Serious Burn
120 °F (48 °C)	More than 5 minutes	140 °F (60 °C)	Less than 5 seconds
125 °F (51 °C)	1.5 to 2 minutes	145 °F (62 °C)	Less than 3 seconds
130 °F (54 °C)	Approx. 30 seconds	150 °F (65 °C)	Approx. 1.5 seconds
135 °F (57 °C)	Approx. 10 seconds	155 °F (68 °C)	Approx. 1 second



Warning

- **Do not store combustibles, such as papers or laundry, near the water heater or venting system.**
Failure to do so may result in fire or explosion.
- **Do not store or use gasoline or other flammable liquids near this water heater.**
Failure to do so may result in fire or explosion.
- **Do not store or use compressed gases, such as hair sprays or spray paints, near the water heater or venting system, including the vent termination.**
Failure to do so may result in fire or explosion.
- **Do not remove the front cover unless the power to the water heater is turned off or disconnected.**
Failure to do so may result in electric shock.
- **Do not touch the internal components of the water heater or the power cord with wet hands.**
Failure to do so may result in electric shock.
- **Do not operate the water heater with the front cover opened.**
Failure to do so may result in fire or carbon monoxide (CO) poisoning, which may result in property damage, personal injury, or death.
- **Do not operate the water heater without proper venting.**
Failure to do so may result in fire or carbon monoxide (CO) poisoning, which may result in property damage, personal injury, or death.



Caution

- **Do not use the water heater for anything other than its intended purpose, as described in this manual.**
Failure to do so may result in property damage, personal injury, or death.
- **Do not turn on the water heater unless the water and gas supplies are fully opened.**
Failure to do so may damage the water heater.
- **Do not use unapproved replacement or accessory parts.**
Failure to do so may result in improper or dangerous operation and will void the manufacturer's warranty.
- **When servicing the controls, label all wires prior to disconnecting them.**
Failure to do so may result in wiring errors.
- **Do not place anything in or around the vent terminals that could obstruct the air flow in or out of the water heater.**
Failure to do so may result in fire or carbon monoxide (CO) poisoning, which may result in property damage, personal injury, or death.
- **This water heater has been approved for use in the USA and Canada only.**
Using the water heater in any other country will void the manufacturer's warranty.

Important Note for the State of Massachusetts

From Massachusetts Rules and Regulations 248 CMR 5.08:

- (a) For all side wall horizontally vented gas fuelled equipment installed in every dwelling, building or structure used in whole or in part for residential purposes, including those owned or operated by the Commonwealth and where the side wall exhaust vent termination is less than seven (7) feet above finished grade in the area of the venting, including but not limited to decks and porches, the following requirements shall be satisfied.
 - 1. **INSTALLATION OF CARBON MONOXIDE DETECTORS.** At the time of installation of the side wall horizontal vented gas fuelled equipment, the installing plumber or gas fitter shall observe that a hard wired carbon monoxide detector with an alarm and battery back-up is installed on the floor level where the gas equipment is to be installed, in addition, the installing plumber or gas fitter shall observe that a battery operated or hard-wired carbon monoxide detector with an alarm is installed on each additional level of the dwelling, building or structure served by the side wall horizontal vented gas fuelled equipment. It shall be the responsibility of the property owner to secure the services of qualified licensed professionals for the installation of hard-wired carbon monoxide detectors.
 - a. In the event that the side wall horizontally vented gas fuelled equipment is installed in a crawl space or an attic, the hard-wired carbon monoxide detector with alarm and battery back-up may be installed on the next adjacent floor level.
 - b. In the event that the requirements of this subdivision cannot be met at the time of completion of installation, the owner shall have a period of thirty (30) days to comply with the above requirements; provided, however, that during said thirty (30) day period, a battery operated carbon monoxide detector with an alarm shall be installed.
 - 2. **APPROVED CARBON MONOXIDE DETECTORS.** Each carbon monoxide detector as required in accordance with the above provisions shall comply with NFPA 720 and be ANSI/UL 2034 listed as IAS certified.
 - 3. **SIGNAGE.** A metal or plastic identification plate shall be permanently mounted to the exterior of the building at a minimum height of eight (8) feet above grade directly in line with the exhaust vent terminal for the horizontally vented gas fuelled heating appliance or equipment. The sign shall read, in print size no less than one-half (1/2) inch in size, "GAS VENT DIRECTLY BELOW. KEEP CLEAR OF ALL OBSTRUCTIONS".
 - 4. **INSPECTION.** The state or local gas inspector of the side wall horizontally vented gas fuelled equipment shall not approve the installation unless, upon inspection, the inspector observes carbon monoxide detectors and signage installed in accordance with the provisions of 248 CMR 5.089(2)(a) 1 through 4.
- (b) **EXEMPTIONS.** The following equipment is exempt from 248 CMR 5.089(2)(a) 1 through 4.
 - 1. The equipment listed in Chapter 10 entitled "Equipment Not Required To Be Vented" in the most current edition of NFPA 54 as adopted by the Board; and
 - 2. Product Approved side wall horizontal vented gas fuelled equipment installed in a room or structure separate from the dwelling, building or structure used in whole or in part for residential purposes.
- (c) **MANUFACTURER REQUIREMENTS – GAS EQUIPMENT VENTING SYSTEM PROVIDED.** When the manufacturer of Product Approved side wall horizontally vented gas equipment provides a venting system design or venting system components with the equipment, the instructions provided by the manufacturer for installation of the equipment and the venting system shall include:
 - 1. Detailed instructions for the installation of the venting system design or the venting system components; and
 - 2. A complete parts list for the venting system design or venting system.
- (d) **MANUFACTURER REQUIREMENTS – GAS EQUIPMENT VENTING SYSTEM NOT PROVIDED.** When the manufacturer of a Product Approved side wall horizontally vented gas fuelled equipment does not provide the parts for venting the fuel gases, but identifies "special venting systems", the following requirements shall be satisfied by the manufacturer.
 - 1. The referenced "special venting system" instructions shall be included with the appliance or equipment installation instructions; and
 - 2. The "special venting systems" shall be Product Approved by the Board, and the instructions for that system shall include a parts list and detailed installation instructions.
- (e) A copy of all installation instructions for all Product Approved side wall horizontally vented gas fuelled equipment, all venting instructions, all parts lists for venting instructions, and/or all venting design instructions shall remain with the appliance or equipment at the completion of the installation.

Table of Contents

Safety Information	2	Installing a Vent	22
Important Note for the State of Massachusetts	4	Vent Type.....	22
General Information.....	6	Vent Pipe Materials.....	26
Included Items	6	Vent Length.....	26
Optional Accessories.....	6	Connecting the Vent Clip	27
Specifications.....	7	Vent Termination	27
Rating Plate	8	Setting the DIP Switches (for Cascade System)	30
Dimensions.....	9	Connecting the Power Supply	31
Components	10	Self-adjusting Mode	32
Installing the Water Heater	12	Installation Checklist.....	34
Installer Qualifications.....	12	Appendix.....	36
Compliance Requirements	12	Gas Conversion	36
Location.....	12	Cascade System	37
Connecting the Gas Supply	15	Wiring Diagram.....	39
Gas Pipe Sizing Tables.....	15	Component Assembly Diagrams and Parts Lists	40
Gas Piping	16	Case Parts.....	40
Inlet Gas Pressure.....	17	Flue Parts.....	42
Connecting the Water Supply	18	Water Parts.....	44
Water Piping.....	18		
Pressure Relief Valve.....	19		
Condensate Drain	20		
Condensate Trap.....	21		

General Information

Included Items

The following items are included with the water heater. Check each of the following items before installation.

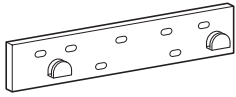

Wall mounting bracket

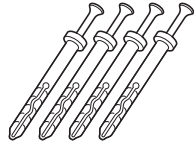

Tapping screws & anchors



Installation and User manual

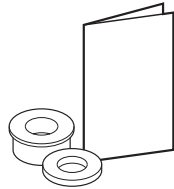

Gas conversion kit

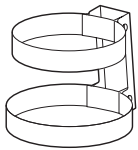

Vent clip



Cascade communication cable

Optional Accessories

The following optional accessories are not included with the water heater, but may be necessary for the installation. Check the need for any of the following optional accessories before installation.

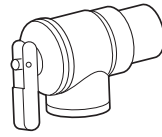

Pressure relief valve

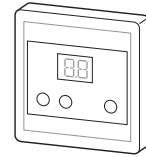

Remote controller

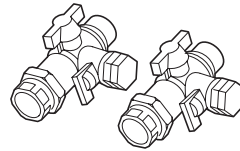

Plumb easy valve set

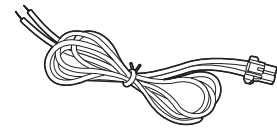

External pump connector (<150W, 1.5A)

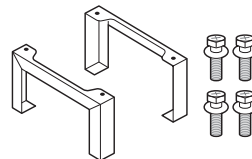

Water heater stand

Notice

If there is a missing item, please contact Technical Support at 1-800-761-0053.

■ Specifications

The following table shows the specifications for the water heater. Additional specifications about water, gas, electric, and air supplies (venting) appear in each installation section.

Item		VH-150	VH-199
Heat Capacity (Input)	Natural Gas	38,000–150,000 BTU/H	38,000–199,000 BTU/H
	Propane Gas	38,000–150,000 BTU/H	38,000–199,000 BTU/H
Thermal Efficiency	Natural Gas	96	94
	Propane Gas	98	97
Flow Rate (DHW)	35°F (19°C) Temp Rise	8.2 GPM (21 LPM)	10.8 GPM (41 LPM)
	45°F (25°C) Temp Rise	6.3 GPM (24 LPM)	8.2 GPM (31 LPM)
	77°F (43°C) Temp Rise	3.8 GPM (14 LPM)	4.8 GPM (18 LPM)
Dimensions (W x D x H)		18.1" x 27.6" x 13.6" (460 mm x 700 mm x 345 mm)	
Weight		92 lbs (42 kg)	
Installation Type		Indoor wall-hung or stand	
Venting Type		Forced draft direct vent	
Ignition		Electronic ignition	
Water Pressure (Max.)		150 psi	
Natural Gas Supply Pressure		3.5"–10.5" WC	
Propane Gas Supply Pressure		8"–13" WC	
Natural Gas Manifold Pressure (Max. ~ Min.)		-0.02" WC – -0.15" WC	-0.02" WC – -0.25" WC
Propane Gas Manifold Pressure (Max. ~ Min.)		-0.01" WC – -0.1" WC	-0.01" WC – -0.15" WC
Reserve Tank		3 Gallons (11 Liters)	
Minimum Flow Rate		0 GPM	
Connection Sizes	Cold Water Inlet	3/4" NPT	
	Hot Water Outlet	3/4" NPT	
	Gas Inlet	3/4" NPT	
Power Supply	Main Supply	120V AC, 60 Hz / use less than 5 APM	
Materials	Heat Exchangers	Stainless steel	
Venting	Exhaust	2" or 3" PVC, CPVC, Polypropylene 2" or 3" Special gas vent type BH (Class II, A/B/C)	
	Intake	2" or 3" PVC, CPVC, Polypropylene 2" or 3" Special gas vent type BH (Class II, A/B/C)	
	Vent Clearances	0" to combustibles	
Safety Devices		Flame rod, APS, Over heat preventer, Exhaust temperature high limit sensor, Power surge fuse	

Rating Plate



The gas type and electricity voltage must match the rating plate. Using a different gas type and electricity voltage will cause the water heater to malfunction.

Before the installation, check the rating plate located on the side of the water heater to ensure that the water heater matches the gas type, gas pressure, water pressure, and electrical supply available in the installation location. If the water heater does not match each of these ratings, do not install the water heater. If the gas conversion is required, the included gas conversion kit must be used.

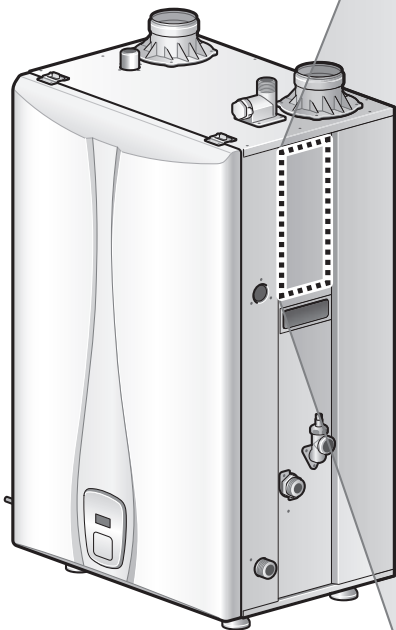

Direct Vent Automatic Instantaneous Water Heater
 Chauffe-eau Automatique Instantan Ventilation Directe
 VESTA. DS, INC.
 2711 LBJ Freeway, Suite#320 Farmers Branch, Texas75234
 Tel / Tél : 1-800-761-0053
 Model / Modèle : VH - 199
 Type of Gas / Type de gaz : Natural Gas / Gaz naturel
 BTU Input / Entrée BTU : Min. 38,000 ~ Max.199,000
 Recovery Rate / Taux de récupération : 251 Gallons/Hour(Δ90°F)
 Inlet Gas Pressure : Min. 3.5 ~ Max. 10.5 inches
 / Pression des gaz dans l'orifice
 Manifold Gas Pressure : Min -0.02 ~ Max. - 0.25 inches
 / Pression des gaz dans le collecteur
 Orifice Size / dimension des injecteurs : 0.3 for NG , 0.24 for LP inches
 Electrical Rating : AC 120 Volts 60Hz Less than 5 Ampere
 / Caractéristiques électriques
 Max. Water pressure : Max. 150psi
 / Pression d'eau maximale
 Suitable for water(potable) heating and space heating and not suitable
 for space heating application only.
 / Convient au chauffage combiné de l'eau (potable) et des locaux,
 mais non au chauffage des locaux seulement.
 ANSI Z21.10.3/CSA 4.3-2014

FOR YOUR SAFETY / Pour votre sécurité
 Do Not Store Or Use Gasoline Or Other Flammable vapors
 and liquids in the vicinity of this or any other appliances
 Ne pas stocker ni utiliser d'essence ou d'autres vapeurs
 ou liquides inflammables autour de cet appareil ou autres
 appareils similaires



REQUIRED CLEARANCES TO COMBUSTIBLES Distance requise par rapport aux matériaux combustibles

Minimum Clearances from Combustible of Non-combustible Construction Distance minimum entre tout matériau combustible et la construction non-combustible	
Clearance / Distance	Indoor Install Installation intérieure
Top of heater / Haut du chauffe-eau	12 inches
Back of heater / Arrière du chauffe-eau	0.6 inches
Front of heater / Avant du chauffe-eau	6 inches
Side of heater / Côtés du chauffe-eau	2 inches (L), 6 inches(R)

PRODUCT NUMBER / Numéro de produit :

SERIAL NUMBER / Numéro de série :

Made in KOREA
 / Fabriqué en Corée

■ Dimensions

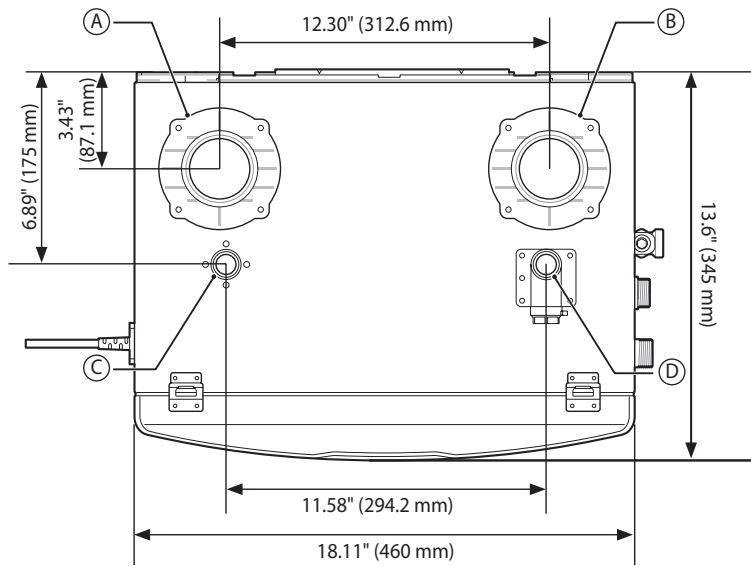

	Description	Diameter
(A)	Air intake connector	2"
(B)	Flue connector	2"
(C)	Hot water outlet	3/4"
(D)	Cold water inlet	3/4"
(E)	Pressure relief valve connector	3/4"
(F)	Drain valve	3/4"
(G)	Condensate outlet	3/4"
(H)	Gas inlet	3/4"

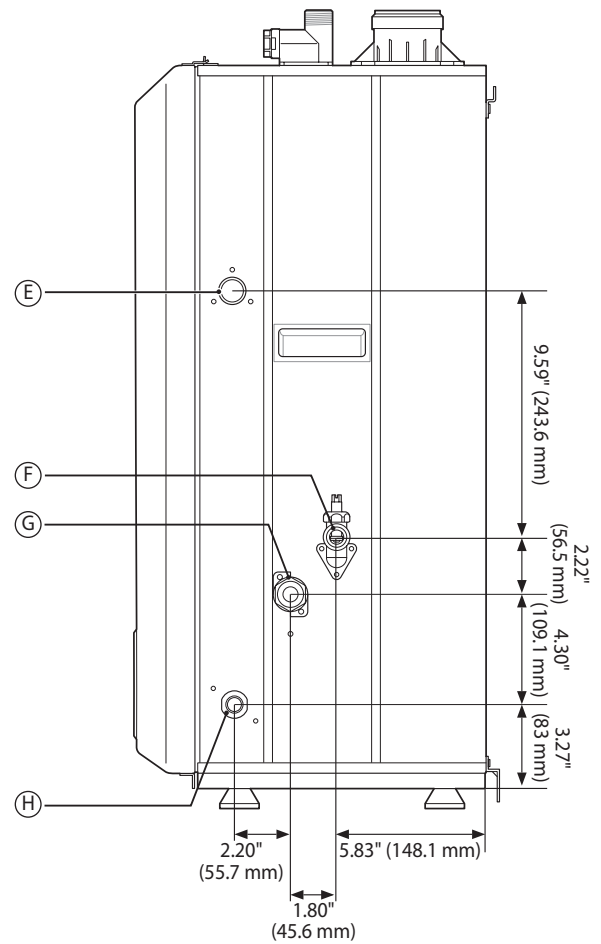
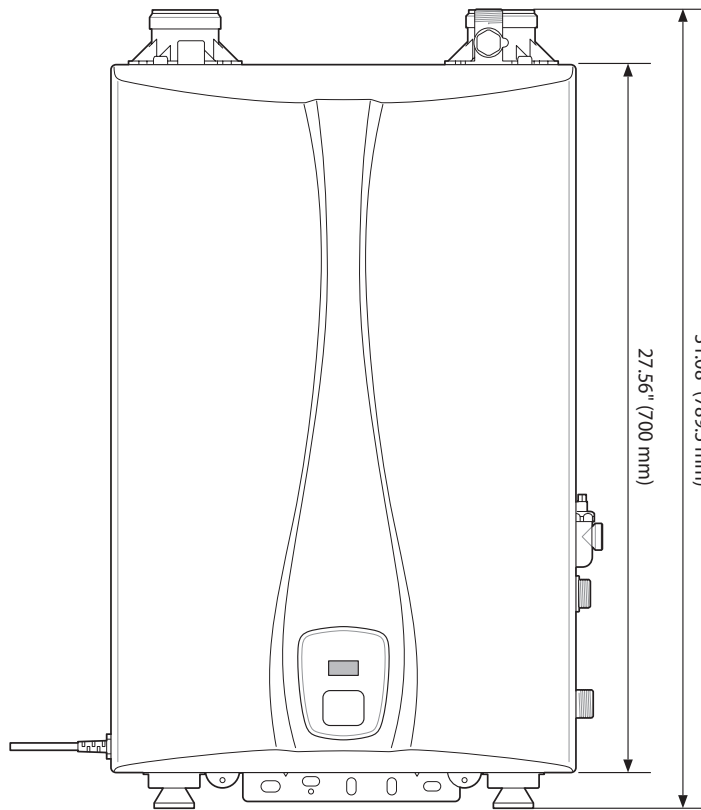

Components

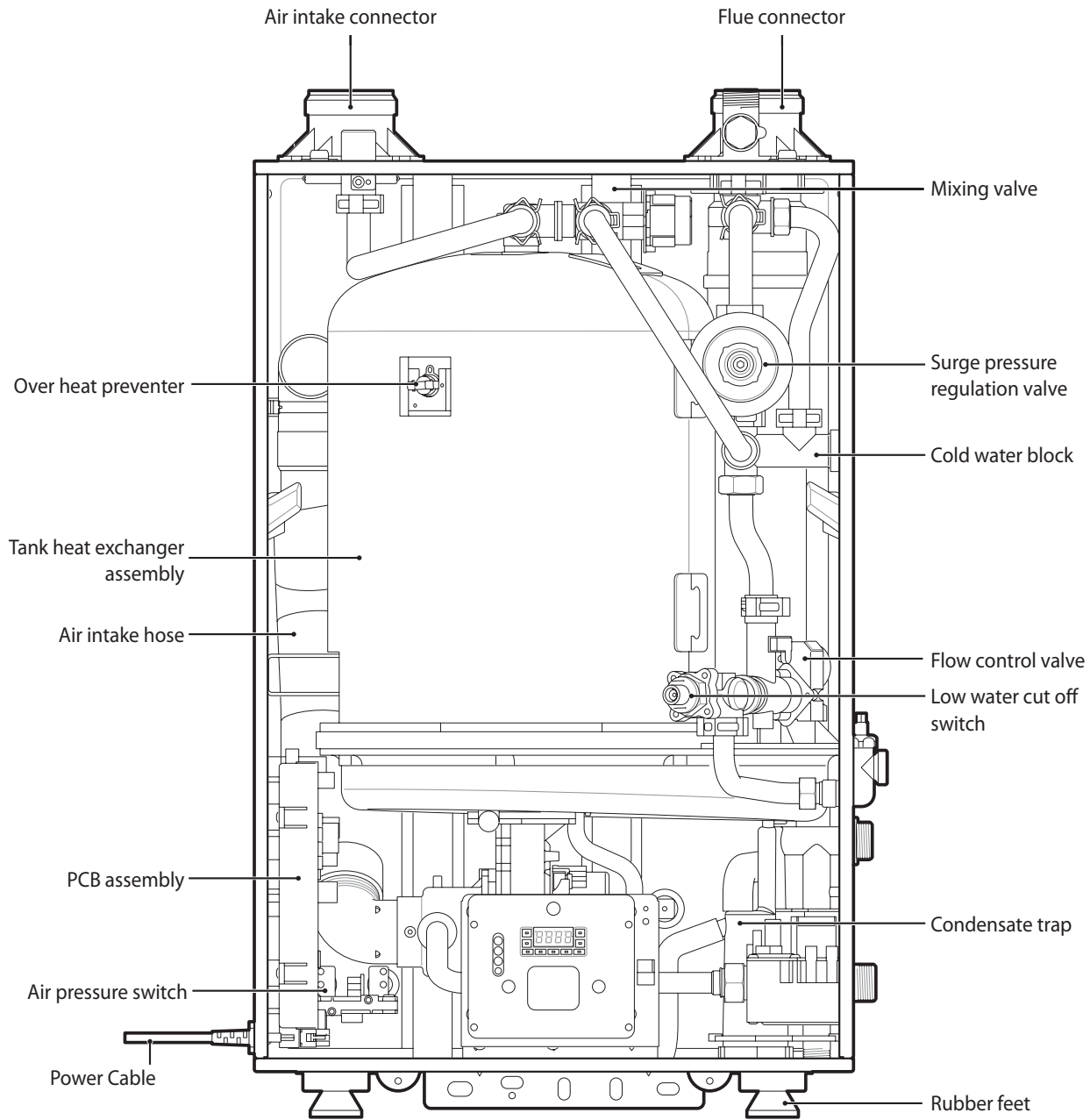

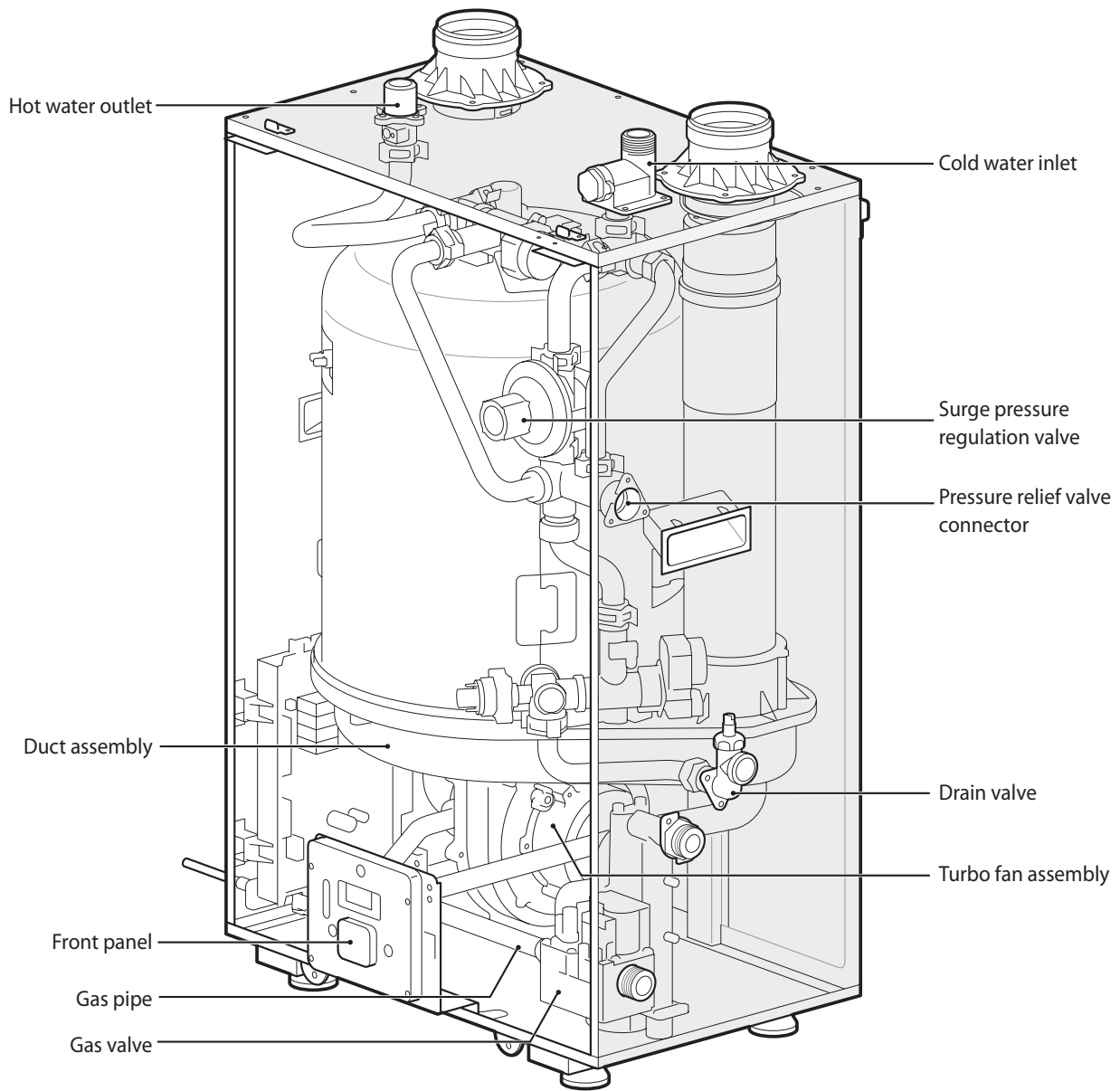

Installing the Water Heater

■ Installer Qualifications

A licensed professional must install and inspect the appliance. A licensed professional is a person who is licensed for the following:

- Connecting gas lines, water lines, valves, electricity
- Vent installation through walls and roofs
- Applicable of local, state, and national codes

■ Compliance Requirements

- National electrical code.
- National fuel gas code, ANSI Z223.1/NFPA 54 and/or CSA B149.1, natural gas and propane installation codes.
- Local, state, provincial, and national codes, laws, regulations, and ordinances.

■ Location

When considering a location for installation, the installer, must ensure the following:

- Access to utilities
- Humidity and contact with water
- Water quality
- Drainage
- Venting and ventilation
- Proximity to fixtures and appliances
- Clearances
- Clean, debris and chemical-free combustion air
- High elevation Installations

● Access to utilities

- Electricity – Close to where the electrical supply enters the building
- Water – Close to where the domestic water supply enters the building
- Gas – Close to where the gas supply enters the building

● Humidity and contact with water

Avoid places with excessive humidity. The water heater has electric gas ignition components. If water gets inside the water heater, the ignition system can be damaged. The water heater must be installed in such a way as to ensure that the gas ignition system components are protected from water (dripping, spraying, rain, etc.) during operation and service.

● Water quality

Water quality can have an impact on appliance longevity and may void the manufacturer's warranty.

To maintain the water heater properly, ensure that your water meets EPA quality standards. The following table shows the maximum contaminant levels allowed, based on the EPA National Secondary Drinking Water Regulations (40 CFR Part 143.3). If you suspect that your water is contaminated in any way, stop using the water heater and contact an authorized technician or licensed professional.

Contaminant	Maximum Allowable Level
Total Hardness	200 mg/l (12 grains/gallon)
Aluminum	0.05 – 0.2 mg/l
Chloride	250 mg/l
Copper	1.0 mg/l
Iron	0.3 mg/l
Manganese	0.05 mg/l
pH	6.5 – 8.5
Sulfate	205 mg/l
Total Dissolved Solids (TDS)	500 mg/l
Zinc	205 mg/l

● Drainage

A significant amount of condensate is produced during the water heater operation. Install the water heater near a suitable drain and where damage from a possible leak will be minimal. Installing the water heater without a drain will void the warranty. For more information about condensate drainage, refer to "Condensate Drain" on page 20.

The water heater must be located in an area where leakage of the unit or connections will not result in damage to the area adjacent to the appliance or to lower floors of the structure. When such locations cannot be found, installation of an adequately-draining drain pan under the water heater is highly recommended. When installing the drain pan, ensure that the installation does not restrict combustion air flow.

● Venting and ventilation

Consider venting restrictions caused by windows, doors, air intakes, gas meters, foliage and other buildings, and select a location that requires minimal venting.

When considering an adequate venting and ventilation, ensure the following:

- Maintain a minimum clearance of 4 feet (1.2 meters) from heating and cooling vents.
- Maintain proper clearances from any openings in the building.
- Install the water heater with a minimum clearance of 12 inches (300 mm) above an exterior grade or as required by local codes.

- Install the exhaust vent in an area that is free from obstructions and does not allow the exhaust to accumulate.
- Do not enclose the vent termination.
- Do not install the water heater where moisture from the exhaust may discolor or damage walls.
- Do not install the water heater in bathrooms, bedrooms, or any other occupied rooms that is normally kept closed or that is not adequately ventilated.

For more information about venting, refer to "Installing a Vent" on page 22.

Clearances

The water heater should be installed in an area that allows for service and maintenance access to utility connections, piping, filters, and traps. Ensure the following clearances are maintained:

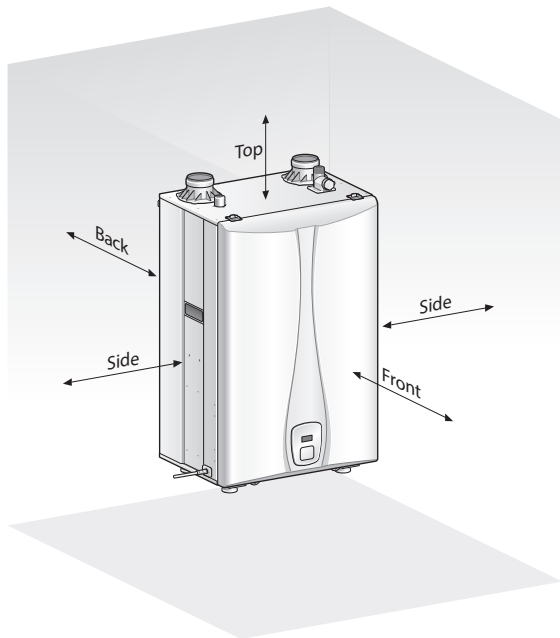

Clearance From	Wall Mounting	Floor Mounting
Top	12 inches (305 mm) min.	12 inches (305 mm) min.
Back	0.6 inches (15 mm) min.	0.6 inches (15 mm) min.
Front	6 inches (152 mm) min.	6 inches (152 mm) min.
Left Side	2 inches (51 mm) min.	2 inches (51 mm) min.
Right Side (gas Piping)	6 inches (152 mm) min.	6 inches (152 mm) min.
Bottom	6 inches (152 mm) min.	6 inches (152 mm) min.

Clean, debris and chemical-free combustion air

- Do not install the water heater in areas where dust and debris may accumulate or where combustion air can be contaminated.
- Do not install the water heater in areas with greasy fumes or heavy amounts of steam, if necessary, take measures to prevent fumes and steam from entering the water heater.
- Chemicals that are corrosive in nature should not be stored or used near the water heater.

High elevation

The water heater can be installed at elevations under 4,500 ft (1,370 m) with no additional settings. If you are installing the water heater at elevations above 4,500 ft (1,370 m), it is recommended that you perform a Self-adjusting Mode. For more information about Self-adjusting Mode, refer to "Self-adjusting Mode" on page 32.

Position



Do not mount the water heater to unsubstantial flooring or unreinforced dry wall.

The water heater can be mounted either on the floor or to the wall. For easy installation, use the mounting bracket to mount the water heater to standard wall studs. If the strength of the wall is insufficient and or if the framing is non-standard or uneven, reinforce the area before installation. If the floor is uneven or not rigid enough to support the water heater, level and reinforce the floor. Avoid installation in unstable locations as the water heater will make some operational noises while it is running.

Notice

Consider vent length and surrounding circumstances when mounting the water heater.

● Mounting on the floor

To mount the water heater on the floor:

- 1 Check that the floor is even and rigid enough to support the water heater.
- 2 Place the water heater 6" (152 mm) above the floor and level the rubber feet for balance.

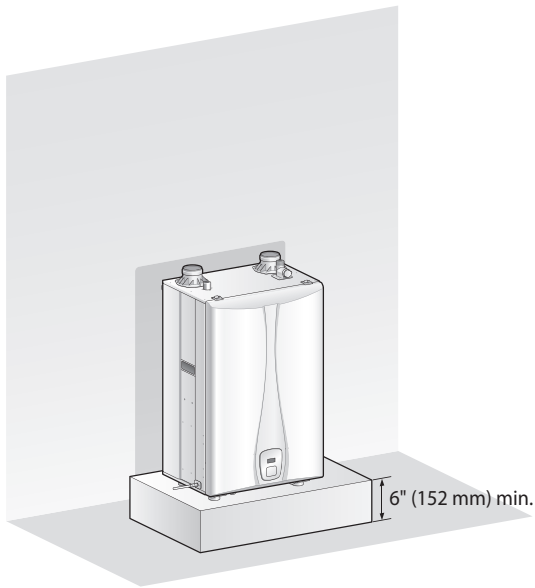

Notice

- To prevent vibration and reduce operational noise, mount the water heater on the floor in front of the wall and use the mounting bracket to affix the water heater to the wall.
- For more information about how to use the mounting bracket, refer to "Mounting to the wall" on page 14.

Water heater stand for commercial food service

Per ANSI/NSF-5, standing directly on a hard surface is not an acceptable installation method. The unit must be elevated at least 6" (152 mm) off the floor. This mounting clearance provides access for clearing any possible debris or accumulated water seepage that may occur beneath the unit.

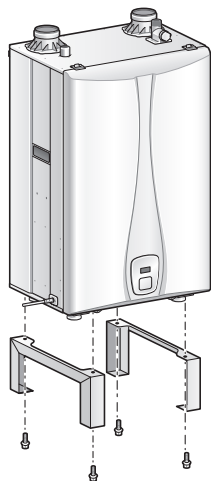

● Mounting to the wall

To mount the water heater to the wall:

- 1 Check that the wall is level and can support the weight of the water heater.
- 2 Affix the mounting bracket securely to the wall.

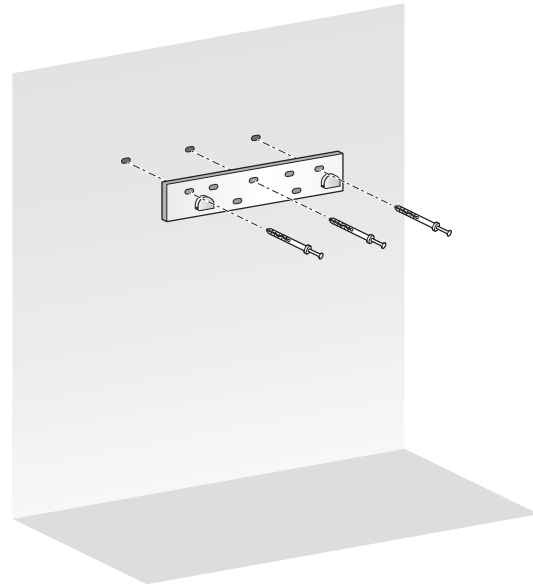

- 3 Align the grooves on the back of the water heater with the tongues on the mounting bracket and hang the water heater from the bracket.

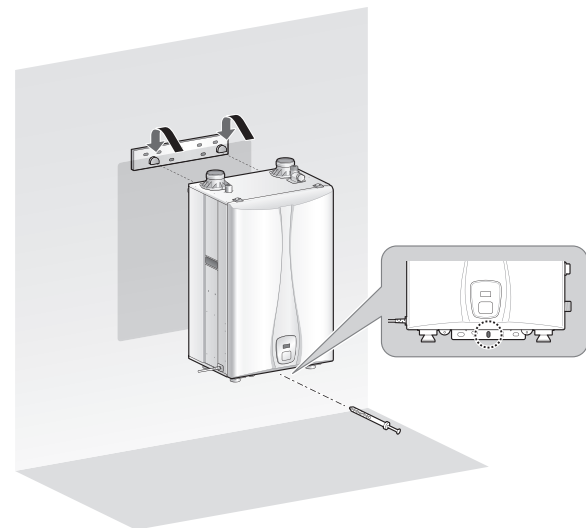

Connecting the Gas Supply

Gas Pipe Sizing Tables

Gas pipe sizing is based on the gas type, supplied gas pressure, pressure drop in the system, and gas line type. The tables below are for reference only (when the gas supply is piping straight to the water heater with no connections to any other gas appliances). For gas pipe sizing, refer to the latest National Fuel Gas code, NFPA 54 and consult the gas pipe manufacturer for actual gas pipe capacities.

Natural gas

Maximum Capacity of Natural Gas Based on a 0.60 specific gravity at a 0.5" WC pressure drop.

Page Size	kBTU/H of Natural Gas												
Length	10'	20'	30'	40'	50'	60'	70'	80'	90'	100'	125'	150'	200'
3/4"	372	255	205	175	156	142	130	121	114	107	95	86	74
1"	702	482	387	331	293	266	245	228	213	202	179	162	139
1 1/4"	1441	990	795	680	603	546	503	468	439	415	367	332	285
1 1/2"	2158	1483	1191	1019	903	819	753	701	658	621	550	499	427
2"	4155	2856	2293	1963	1740	1576	1450	1349	1266	1195	1060	960	822

Liquid propane gas

Maximum Capacity of propane (LP) Gas Based on 11" WC supply pressure at a 1.0" WC pressure drop.

Page Size	kBTU/H of Propane Gas												
Length	10'	20'	30'	40'	50'	60'	70'	80'	90'	100'	125'	150'	200'
3/4"	567	393	315	267	237	217	196	185	173	162	146	132	112
1"	1071	732	590	504	448	409	378	346	322	307	275	252	213
1 1/4"	2205	1496	1212	1039	913	834	771	724	677	630	567	511	440
1 1/2"	3307	2299	1858	1559	1417	1275	1181	1086	1023	976	866	787	675
2"	6221	4331	3465	2992	2646	2394	2205	2047	1921	1811	1606	1496	1260

Gas Piping



Danger

- Do not connect to an unregulated or high pressure propane line or to a high pressure commercial natural gas line.
- The water heater must be isolated from the gas supply piping system during any pressure testing of that system at test pressures equal to or more than 0.5 psig.



Warning

- Only a licensed professional should connect the gas supplies.
- Before connecting the gas supply, determine the gas type and pressure for the water heater by referring to the rating plate. Using a different gas type will result in abnormal combustion and malfunction of the water heater causing fire or explosion.
- Leak test the appliance and its gas connection before operating the water heater.
- Do not attempt a field conversion without a Vesta conversion kit. Use the Vesta conversion kit to convert from natural gas to propane or vice versa. Failure to do so may result in dangerous operating conditions and will void the warranty.

In the United States: The installation must conform with local codes or, in the absence of local codes, the National Fuel Gas Code ANSI Z223.1/NFPA 54.

In Canada: The Installation must conform to CGA B149 INSTALLATION CODES and/or local installation codes.

To ensure a sufficient gas supply, it is recommended that the water heater be the first appliance to be connected to the gas supply line.

To connect the gas supply:

- 1 Determine the gas type and pressure by referring to the rating plate.
- 2 Perform a pressure test on the main gas supply line.
- 3 Purge the gas line of any debris.
- 4 Determine the proper type and size for the gas line. Refer to the gas pipe sizing tables on page 15.
- 5 Install a union.
- 6 Install a manual gas shut off valve on the gas supply line within easy reach of the appliance.



Warning

- Improper installation of the manual gas shut-off valve may result in property damage, personal injury or death.
- Only a licensed professional, in accordance with the ANSI Z21.1/CSA 9.1, should install the manual gas shut-off valve.

7 Connect the gas supply line.

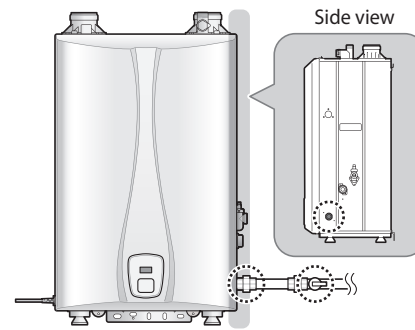

8 Check for gas leaks at all joints.



Notice

- Tighten the water heater connection valves with care to avoid damage.
- Apply gas leak detection solution to all gas fittings.
- The minimum internal diameter required for any appliance connector is $\frac{3}{4}$ ".
- When using flexible gas lines, ensure that the pipe's inner diameter and connector is sufficient to supply the required BTUs. Also, ensure that the flexible line has no crimps or tight bends in it, as this will restrict gas flow.
- To facilitate any future maintenance or service, the installation of a union on the gas supply line close to the water heater is recommended.

- The following is a LP gas piping example for the single regulator system

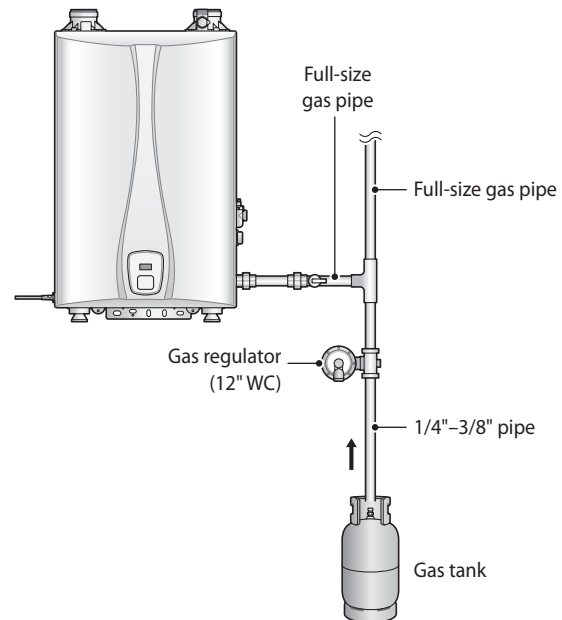

- The following is an LP gas piping example for the 2-lb. system with multiple regulators.

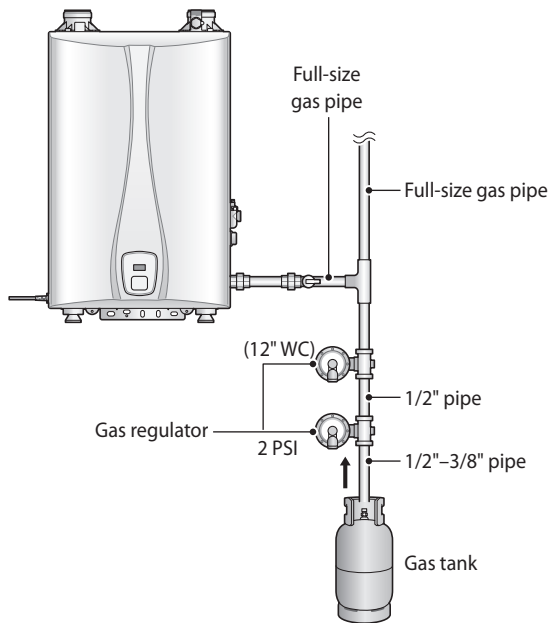

Inlet Gas Pressure



Warning

Inlet gas pressure should be measured by a licensed professional only. The water heater cannot function properly without sufficient inlet gas pressure.

- The water heater must be isolated from the gas supply piping system during any pressure testing of that system at test pressures equal to or more than 0.5 psig. If overpressure has occurred, through improper testing of the gas lines or malfunction of the supply system, the gas valve must be checked for safe operation.
- The inlet gas pressure must be maintained between 3.5" and 10.5" WC for natural gas and between 8" and 13" WC for liquefied propane.

To measure the inlet gas pressure:

- 1 Open a hot water faucet. The water heater should turn on and the gas in the gas supply line will be purged.
- 2 Leave the faucet on until the water heater shuts down due to a lack of gas supply, and then turn off the hot water faucet.
- 3 Remove the water heater front cover by loosening the 2 Phillips screws securing it to the case.

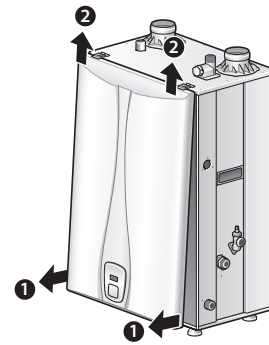

- 4 Loosen the screw indicated in the figure below and connect a manometer to the pressure port. Reset the manometer to zero before use.

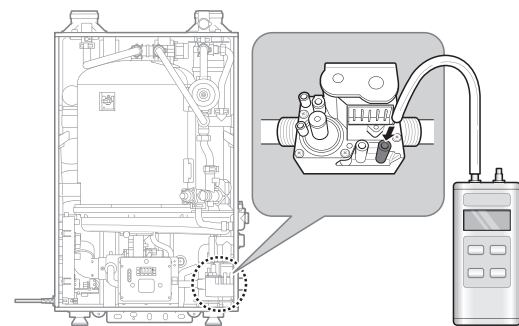

- 5 Re-open the manual gas shut-off valve and check for leaks.
- 6 Open multiple fixtures that have high flow rates, such as bathtub and shower faucets, to ramp up the water heater to its maximum firing rate.
- 7 When the water heater reaches its maximum firing rate, check the inlet gas pressure reading on the manometer. The gas pressure must fall within the ranges specified in "Gas Pipe Sizing Tables" on page 15.

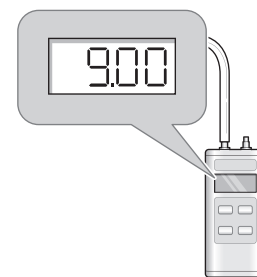

- 8 Tighten the inlet gas pressure screw.
- 9 Replace the front cover and tighten the 2 Phillips screws to secure it to the case.

Connecting the Water Supply

Water Piping



Warning

- Before installing the water heater, flush the water line to remove all debris, and after installation is complete, purge the air from the line. Failure to do so may cause damage to the water heater.
- Do not use lead, PVC, iron or any piping which has been treated with chromates or other chemicals.
- Do not use this water heater if any part has been immersed in water. Immediately call a licensed professional to inspect the water heater and replace any damaged parts.
- Do not reverse the hot outlet and cold inlet connections to the water heater. This will cause the water heater to not operate properly.

The water fittings on the water heater are 3/4". If the installation site has only 1/2" plumbing throughout, it is not necessary to upsize the water lines to 3/4", if you are installing a single water heater. When installing multiple water heaters, the number of water heaters and pipe sizing required will depend on the total hot water demand. For information about pipe sizing for multiple water heaters, refer to "Piping sizes" on page 37.

When connecting the water supply, follow these guidelines:

- Use only pipes, fittings, valves, and other components (such as solder), that are approved for use in potable water systems.
- Tighten the water heater connection valves with care to avoid damage.
- Use unions and manual shut-off valves on the cold water inlet, DHW outlet, and recirculation water inlet.
- Strive to make the hot water piping system as short as possible, so as to deliver hot water to the fixtures more quickly and reduce heat loss.
- To conserve water and energy, insulate all water piping—especially the hot and recirculation water lines. Never cover the drain or pressure relief valve. If the water heater is installed in a closed water supply system, such as one having a backflow preventer in the cold water supply line, means shall be provided to control thermal expansion. Contact the water supplier or local plumbing inspector for information about how to control this situation.
- Install a pressure meter on the inlet. If this is not done, local boiling will occur inside the water heater causing abnormal sounds and decreasing the durability of the heat exchanger.
- After installing the water heater, clean the inlet water filter that is located inside the cold water inlet, and then test the water heater for proper flow and inspect for leaks. Instruct the water heater owner that the filter must be cleaned periodically to maintain proper water flow.
- When all plumbing work is completed, check for leaks and take corrective action before proceeding.

- The following is a water piping example for the water heater:

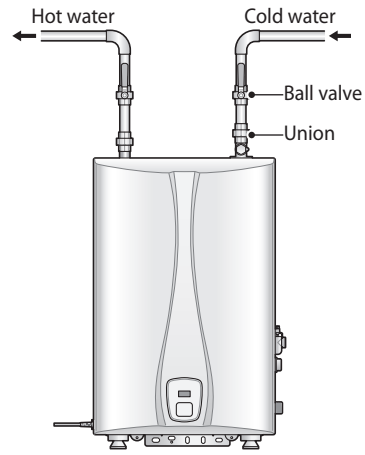

- The following is a recirculation system piping example for the water heater (external pump):

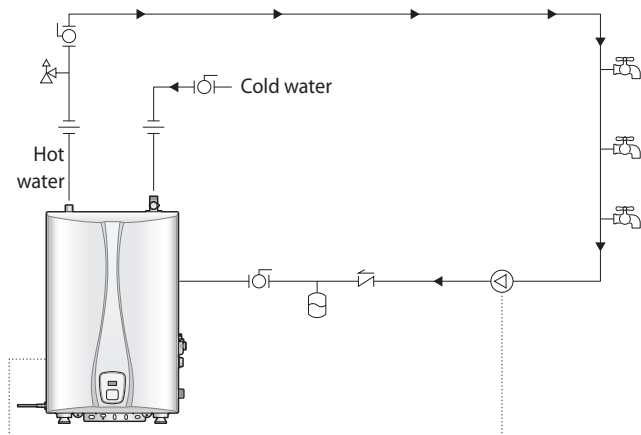

- | | |
|-----------------------|------------------|
| Ball valve | Circulation pump |
| Union | Check valve |
| Pressure relief valve | Faucet |
| Expansion tank | |

Notice

- When using a recirculation mode, by keeping the water in the hot water supply pipe hot, you can get instant hot water when you turn the tap on. On the other hand, there will be some minor efficiency loss, as a result of the water heater maintaining a steady temperature within the circulation loop, although in many cases, higher gas usage will be compensated for by lower water usage.
- To use the external pump, connect the external pump and PCB by using the external pump connector.
- Power consumption of the external pump must be lower than 150W.

- The following is a single water heater with storage back up for small volume usage:

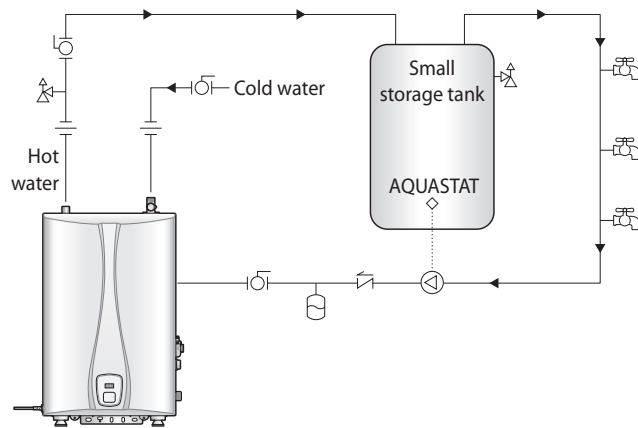

- | | |
|-------------------------|--------------------|
| ⊗ Ball valve | ⊙ Circulation pump |
| ⊏ Union | ⊗ Check valve |
| ⊕ Pressure relief valve | ⊕ Faucet |
| ⊕ Expansion tank | |

- The following is a single water heater with storage back up for large volume usage:

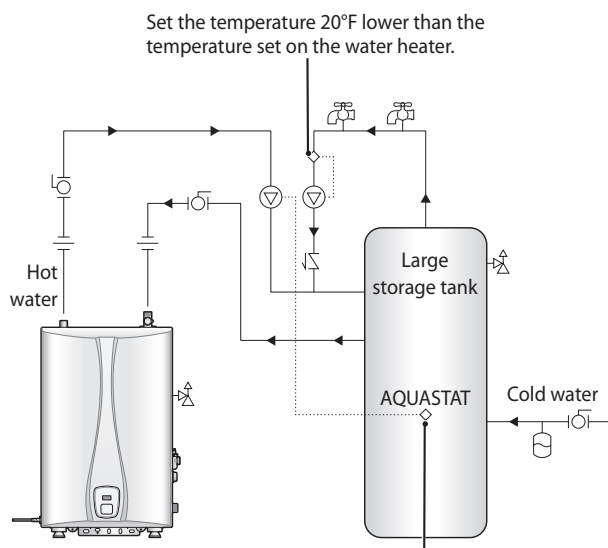

- | | |
|-------------------------|--------------------|
| ⊗ Ball valve | ⊙ Circulation pump |
| ⊏ Union | ⊗ Check valve |
| ⊕ Pressure relief valve | ⊕ Faucet |
| ⊕ Expansion tank | |

Pressure Relief Valve



Warning

Improper installation of the pressure relief valve may result in property damage, personal injury, or death. Follow all instructions and guidelines when installing the pressure relief valve. Only a licensed professional should install the valve.



Caution

The pressure relief valve must conform to the current edition of ANSI Z21.22 or CAN 1-4.4 and installation must follow local codes.

This water heater does not come with an approved pressure relief valve. To complete the installation of the water heater, you must install an approved 3/4", maximum 150 PSI pressure relief valve on the pressure relief valve connector.

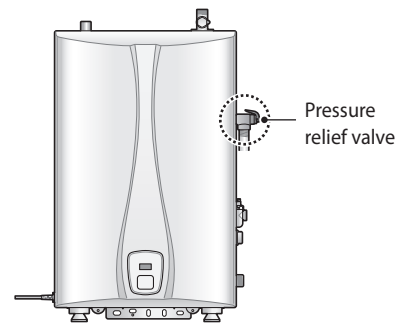

Notice

In recirculating system, install the pressure relief valve on the hot water outlet. The pressure relief valve should be placed as close to the water heater as possible. No other valve should be placed between the pressure relief valve and the water heater.

When installing the valve, follow these guidelines:

- Ensure that the discharge capacity of the pressure relief valve is equal to or greater than the maximum pressure rating of the water heater.
- Ensure that the maximum BTU/H rating on the pressure relief valve is equal to or greater than the maximum input BTU/H rating of the water heater.
- Direct the discharge piping of the pressure relief valve so that hot water will not splash on any person or equipment near by.
- Attach the discharge line to the pressure relief valve and run the end of the line to within 6-12" (150-300mm) of the floor.
- Ensure that the discharge line will allow free and complete drainage with no restriction. Do not install a reducing coupling or other restriction on the discharge line.
- If the relief valve discharges periodically, this may be due to thermal expansion in a closed water supply system. Contact the water supplier or local plumbing inspector on how to correct this situation. Do not plug the relief valve.
- The pressure relief valve must be manually operated periodically to check for correct operation.

Condensate Drain



Caution

- All condensate must drain and be disposed of according to local codes.
- Do not cap or plug the integrated condensate line. If prevented from draining, condensate can damage the water heater.
- The condensate line must have a negative slope to drain properly.
- Do not run drain outdoors. Freezing of condensate can cause property damage.
- Do not connect the condensate drain line directly to the rain sewer.
- Do not connect the condensate drain line with an air conditioning evaporator coil drain.
- Use only corrosion resistant materials for the condensate drain lines such as PVC pipe or plastic hose.
- The end of the condensate drain pipe should be open to the atmosphere. The end should not be under water or other substances.

The Vesta water heater creates condensation when it operates. This condensation has an acidic pH of 3-5. Follow all local codes and regulations when disposing of condensate from the water heater. We recommend draining the condensate into a laundry tub, as the alkali in laundry detergent will neutralize the acid in the condensate. However, other suitable waste drain locations may be used according to local codes.

Before connecting the condensate drain, choose one of the following disposal options:

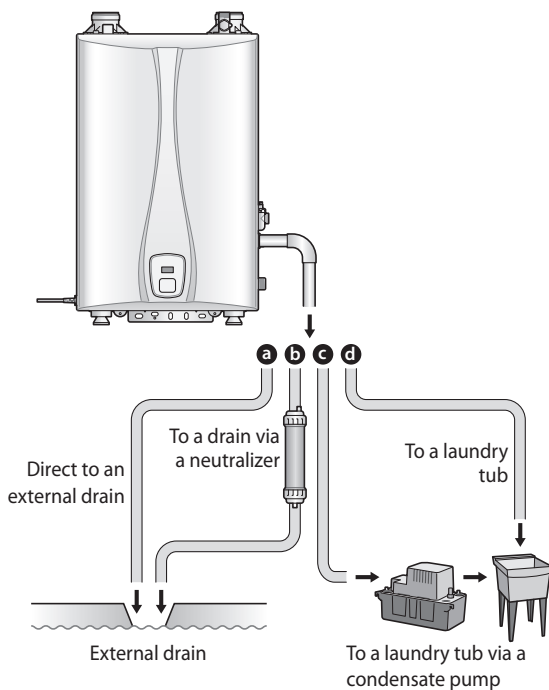

- (A) From the water heater directly into an external drain.
 (B) From the water heater, through a neutralizing agent, and then into an external drain.

Notice

- If you choose this option, the neutralizing agent must be replaced periodically. Depletion of the neutralizing agent will vary, based on the usage rate of the water heater. During the first year of operation, the neutralizer should be checked every few months for depletion and replaced as needed.

- (C) From the water heater into a condensate pump, and then into a laundry tub.

Notice

A pump can be used when there is a long distance between the water heater and the laundry tub or when the bottom of the water heater is lower than the top of the laundry tub.

- (D) From the water heater into a laundry tub.

Notice

The bottom of the water heater must be higher than the top of the laundry tub to use this option. The condensate line must have a negative slope to drain properly.

To connect the condensate drain:

- 1 Connect a drain line to the water heater.

Notice

Use only corrosion-resistant material for the drain line, such as PVC or CPVC. Do not reduce the size of this fitting or the drain line to less than 1/2".

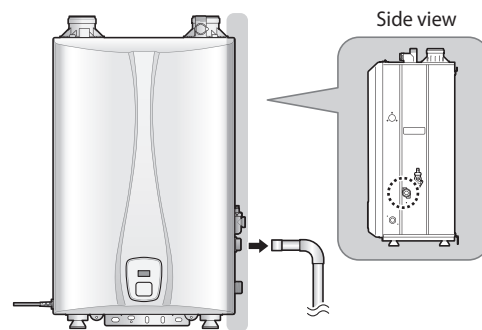

- 2 Place the free end of the drain line into an appropriate drain.

Notice

- If you are using a condensate pump, ensure that the pump allows for up to 2 GPH of drainage for each water heater in the system.
- If you are not using a condensate pump, ensure that the drain line is pitched downward at a minimum slope of 1/4" per foot.

■ Condensate Trap

Before operating the water heater, fill the condensate trap with water through the flue connector. The water heater may be severely damaged unless filled with water prior to operation. Pour 0.1 gallon (400 ml) of water into the exhaust duct. Deflate air sufficiently or equip the air vent with an outlet pipe prior to filling the condensate trap with water (there must be no air inside the heat exchanger).

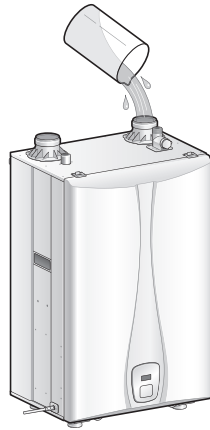

Installing a Vent



Warning

Improper venting of the water heater can result in excessive levels of carbon monoxide, which can lead to severe personal injury or death. This water heater must be vented in accordance with the "Venting of Equipment" section of the latest edition of the ANSI Z223.1/NFPA 54 Natural Fuel Gas Code in the USA and/or the "Venting systems and air supply for water heaters" section of the latest version of the CAN/CGA B149.1 Natural Gas and Propane Installation Code in Canada, as well as all applicable local building codes and regulations. Follow all instructions and guidelines when venting the water heater. Venting should be performed only by a licensed professional.

The water heater must be properly vented to ensure a constant supply of clean intake air and to ensure that exhaust air is properly removed from living areas. When venting the water heater, follow these guidelines:

- Do not install the water heater in areas with contaminated air (containing a high level of dust, sawdust, sand, flour aerosols, or any other such airborne contaminants), as contaminants can cause operational problems. The warranty does not cover damage caused by contaminants in the installation area. If you must install the water heater in an area with contaminated air, use direct venting to supply air from outside the building. We recommend regular filter cleaning and maintenance in these areas.
- For best results, keep the venting system as short and straight as possible.
- Locate the water heater as close as possible to the vent termination.
- Do not connect the water heater vent to a vent for any other gas water heater or vent stack.
- For horizontal runs, slope the horizontal section upward toward the vent termination at a rate of 1/4" per foot (2% slope).
- Create an airtight seal at each joint in the exhaust and intake air pipes from the water heater collar to the vent termination.
- To avoid moisture and frost build-up and to maintain clearances to openings on adjacent homes, 45° elbows, 90° elbows, or tees may be attached to the end of the termination vent pipe to direct the exhaust fumes away from buildings, as long as the restrictions on total allowable vent lengths, maximum number of elbows, and distances to air intake are observed.
- Do not store hazardous or flammable substances near the vent termination.
- If this water heater is to be installed in an area where snow is known to accumulate, protect the vent termination from blockage.
- Ensure that the vent termination is at least 12" (305mm) above ground, or as required by local codes.
- Support the vent pipe with hangers at regular intervals or as required by local codes.
- Exhaust and intake air pipes must be supported at least every 4 feet (1.2m).
- The vent for this appliance shall not terminate over public walkways; or near soffit vents or crawl space vents or where condensate or vapor could create a nuisance or hazard or cause property damage; or where condensate or vapor could cause damage or could be detrimental to the operation of regulators, relief valves, or other equipment.

Vent Type

All water heaters are prepared at the factory to be direct vent (sealed combustion) water heaters that draw all of their required combustion air directly from outside the building. Vesta recommends direct air vent installations whenever possible to avoid back drafting cold air through the water heater. If you cannot use a direct vent, ensure that an ample supply of make-up air is available in the installation location. Vesta also recommends installing a new vent system with this appliance. If reusing an existing vent system, thoroughly inspect it for punctures, cracks, or blockages prior to connecting it to the water heater.

Direct

The water heater uses 2" or 3" diameter exhaust and 2" or 3" diameter intake air ducts. To ensure the draw of air directly from and exhaust of air directly to the outside of the building, create an airtight seal from the water heater collar to the vent termination. Intake materials can be made of ABS, PVC, CPVC, PP, galvanized steel, corrugated aluminum or any other similar materials. If you use a corrugated material, ensure that there is not inadvertent crimping of, or damage to, the intake air pipe.

When using direct venting, maintain the following venting clearances, as required by ANSI Z21.10.3 and the National Fuel Gas Code, ANSI Z223.1/NFPA 54, and CAN/CGA B149.1 Natural Gas and Propane Installation Code.

To use direct venting for the water heater:

- Install the 2" vent directly. Ensure the vent is properly seated.
- To install the 3" vent, reducer (3" to 2") must be used.

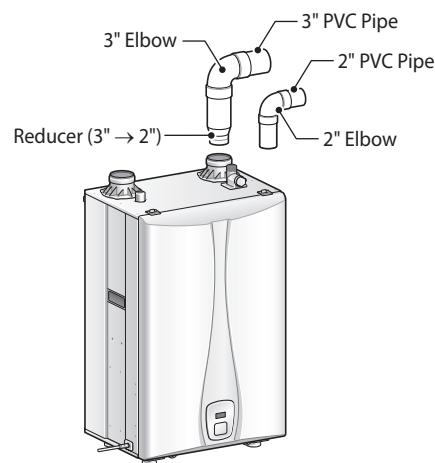

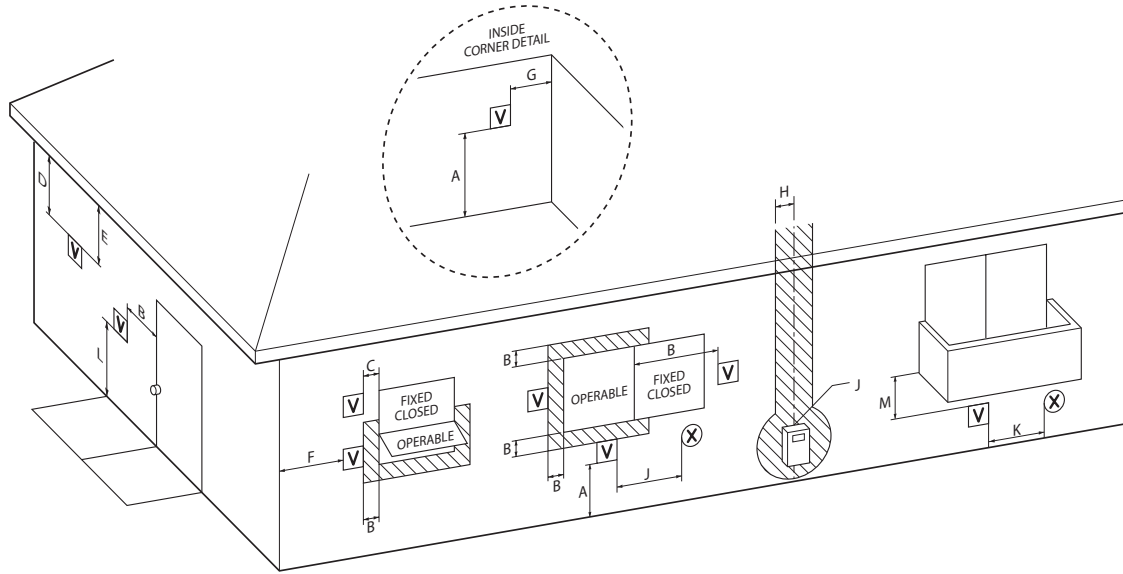

V VENT TERMINAL

X AIR SUPPLY INLET

▨ AREA WHERE TERMINAL IS NOT PERMITTED

		Canadian installations ¹⁾	U.S. installations ²⁾
A	Clearance above grade, veranda, porch, deck or balcony	12 in. (30 cm)	12 in. (30 cm)
B	Clearance to window or door that may be opened	36 in. (91 cm)	12 in. (30 cm)
C	Clearance to permanently closed window	*	*
D	Vertical clearance to ventilated soffit located above the vent termination within a horizontal distance of 2 feet (61 cm) from the center line of the termination	*	*
E	Clearance to unventilated soffit	*	*
F	Clearance to outside corner	*	*
G	Clearance to inside corner	*	*
H	Clearance to each side of center line extended above meter/regulator assembly	36 in. (91 cm) within a height 15 feet above meter/ regulator assembly	*
I	Clearance to service regulator vent outlet	36 in. (91 cm)	*
J	Clearance to non-mechanical air supply inlet to building or the combustion air inlet to any other application	36 in. (91 cm)	12 in. (30 cm)
K	Clearance to mechanical air supply inlet	72 in. (182 cm)	36 in. (91 cm) above if within 10 feet horizontally
L	Clearance above paved sidewalk or paved driveway located on public property	84 in. (236 cm) ³⁾	*
M	Clearance under veranda, porch deck or balcony	12 in. (30 cm) ⁴⁾	*

1) In accordance with the current CSA B149.1 Natural Gas and Propane Installation Code.

2) In accordance with the current ANSI Z223.1 / NFPA 54 National Fuel Gas Code.

3) A vent shall not terminate directly above a sidewalk or paved driveway that is located between two single family dwellings and serves both dwellings.

4) Permitted only if veranda, porch, deck or balcony is fully open on a minimum of two sides beneath the floor.

[*] For clearances not specified in ANSI Z223.1 / NFPA 54 or CSAB149.1, one of the following shall be indicated:

a) A minimum clearance value determined by testing in accordance with section 2.20, or;

b) A reference to the following footnote:

“Clearance in accordance with local installation codes and the requirements of the gas supplier.”

Non-direct

If, at any time, the installation location could experience negative pressure, there is a possibility of back-drafting cold air through the water heater's heat exchanger. This situation could lead to the freezing of the heat exchanger and malfunction of the water heater. However, building codes in most jurisdictions disallow negative pressures in residences. In a home with a well-balanced air supply, the heat exchanger should not be in danger of freezing. Because the cause of back-drafting is not considered a manufacturing problem, any freezing damage which occurs from back-drafting will not be covered by the Vesta warranty. If there is any question about the possibility of back-drafting in the installation location, use a direct venting system for the water heater. When installed in a manufactured home (mobile home), all combustion air must be supplied from the outdoors as described on page 26. When using non-direct venting, maintain non-direct vent clearances shown on page 29 as required by ANSI Z21.10.3 and the National Fuel Gas Code, ANSI Z223.1/NFPA 54, and CAN/CSA B149.1 Natural Gas and Propane Installation Code.

To use non-direct venting for the water heater:

- Insert the elbow into the intake air duct.

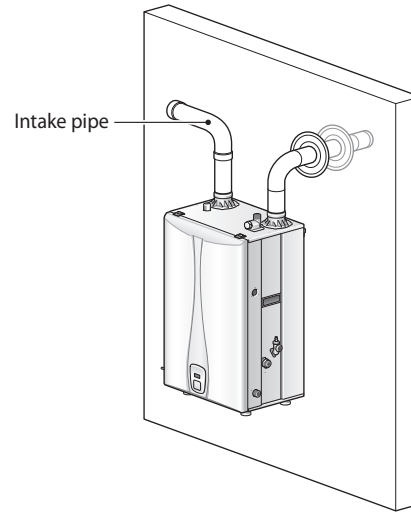

- Provide two openings to allow for circulation of combustion air as specified by ANSI Z223.1/NFPA 54 or CAN/CGA B-149.1:

	VH-150	VH-199
Maximum Input (BTU/H)	150,000	199,900
If outdoor make up air is provided, a minimum free area of 1 in ² per 4,000 BTU/H	40 in ² 10" (W) x 4" (H) or 3" round	50 in ² 10" (W) x 5" (H) or 3" round
If indoor make up air is provided, a minimum free area of 1 in ² per 1,000 BT/H	150 in ² 12 1/4" (W) x 12 1/4" (H)	199 in ² 14 1/4" (W) x 14 1/4" (H)

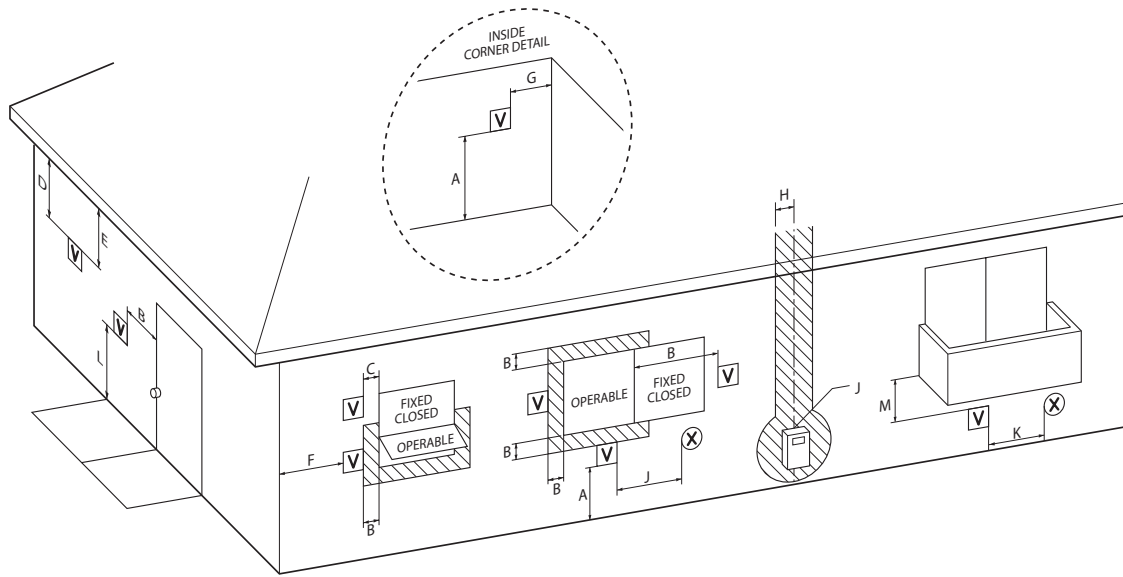

V VENT TERMINAL

X AIR SUPPLY INLET

X AREA WHERE TERMINAL IS NOT PERMITTED

		Canadian installations ¹⁾	U.S. installations ²⁾
A	Clearance above grade, veranda, porch, deck or balcony	12 in. (30 cm)	12 in. (30 cm)
B	Clearance to window or door that may be opened	36 in. (91 cm)	4 feet below or to side of opening; 1 foot above opening
C	Clearance to permanently closed window	*	*
D	Vertical clearance to ventilated soffit located above the vent termination within a horizontal distance of 2 feet (61 cm) from the center line of the termination	*	*
E	Clearance to unventilated soffit	*	*
F	Clearance to outside corner	*	*
G	Clearance to inside corner	*	*
H	Clearance to each side of center line extended above meter/regulator assembly	36 in. (91 cm) within a height 15 feet above meter/ regulator assembly	*
I	Clearance to service regulator vent outlet	36 in. (91 cm)	*
J	Clearance to non-mechanical air supply inlet to building or the combustion air inlet to any other application	36 in. (91 cm)	4 feet below or to side of opening; 1 foot above opening
K	Clearance to mechanical air supply inlet	72 in. (182 cm)	36 in. (91 cm) above if within 10 feet horizontally
L	Clearance above paved sidewalk or paved driveway located on public property	84 in. (236 cm) ³⁾	84 in. (236 cm)
M	Clearance under veranda, porch deck or balcony	12 in. (30 cm) ⁴⁾	*

1) In accordance with the current CSA B149.1 Natural Gas and Propane Installation Code.

2) In accordance with the current ANSI Z223.1 / NFPA 54 National Fuel Gas Code.

3) A vent shall not terminate directly above a sidewalk or paved driveway that is located between two single family dwellings and serves both dwellings.

4) Permitted only if veranda, porch, deck or balcony is fully open on a minimum of two sides beneath the floor.

[*] For clearances not specified in ANSI Z223.1 / NFPA 54 or CSAB149.1, one of the following shall be indicated:

a) A minimum clearance value determined by testing in accordance with section 2.20, or;

b) A reference to the following footnote:

“Clearance in accordance with local installation codes and the requirements of the gas supplier.”

Vent Pipe Materials



Caution

Use of cellular core PVC (ASTM F891), cellular core CPVC, or Radel® (polyphenylsulfone) in non-metallic venting systems is prohibited. Covering non-metallic vent fittings with thermal insulation is prohibited.

Venting requirements differ in the USA and Canada. Consult the following chart or the most recent edition of ANSI Z223.1/NFPA 54 or CAN/CGA B149.1, as well as all applicable local codes and regulations when selecting vent pipe materials. Do not use cellular core-based pipe materials for the exhaust vent.

Locale	Recommended Vent Materials
USA	<ul style="list-style-type: none"> PVC Schedule 40 (solid core) CPVC Schedule 40 or 80 (solid core) Approved Polypropylene
Canada*	<ul style="list-style-type: none"> Type BH Special Gas Vent Class IIA (PVC) Type BH Special Gas Vent Class IIB (CPVC) Type BH Special Gas Vent Class IIC (Polypropylene)

* For installation in Canada, field-supplied plastic vent piping must comply with CAN/CGA B149.1 (latest edition) and be certified to the Standard For Type BH Gas Venting Systems, ULC-S636. Components of this listed system must not be interchanged with other vent systems or unlisted pipes or fittings. All plastic components and specified primers and glues of the certified vent system must be from a single system manufacturer and must not be intermixed with another system manufacturer's parts. The supplied vent connector and vent termination are certified as part of the water heater.

Vent Length

The maximum vent length when using 2" exhaust ducts is 50'. The maximum vent length when using 3" vent ducts is 100'. The intake duct length can be of equal length to the exhaust duct length. Both maximum lengths are reduced by the number of elbows used, as shown in the following table:

Vent Size	Maximum Length	Maximum # of Elbows	Equivalent Lengths
2"	50' (15 m)	5	Reduce the maximum vent length accordingly for each elbow used: <ul style="list-style-type: none"> Each 90° elbow equates to 8 linear feet (2.4 m) of vent Each 45° elbow equates to 4 linear feet (1.2 m) of vent
3"	100' (30 m)	6	Reduce the maximum vent length accordingly for each elbow used: <ul style="list-style-type: none"> Each 90° elbow equates to 5 linear feet (1.5 m) of vent Each 45° elbow equates to 3 linear feet (0.9 m) of vent



Notice

- The maximum length does not include any elbows.
- If using a concentric termination as shown on pages 27, count this as 8 linear feet (2.4 m) of vent.

■ Connecting the Vent Clip



Caution

To connect the exhaust vent firmly, must use the vent clip included with water heater.

To connect the vent clip:

- 1 Connect the vent clip to the exhaust vent.



- 2 Connect the exhaust vent and the vent clip to the flue connector.

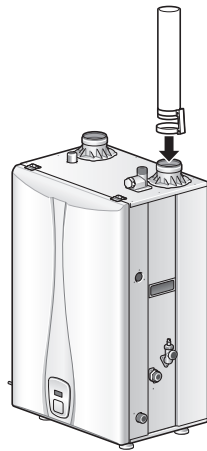

■ Vent Termination



Caution

- Air intake must be protected from any debris.
- When connecting the air intake connector and the flue connector with the vent, connecting parts must be sealed with PVC, glue and high temp silicon.
- Maintain 12" (300 mm) min. (18" (450 mm) min. for Canada) clearance above highest-anticipated snow level. Maximum of 24" (600 mm) above roof.
- Install a bird screen at the end of the intake air pipe.

Determine what type of vent termination is appropriate for the installation location and situation before installing the water heater. The following subsections describe some venting configurations, but do not include all possible options.

● Single-pipe sidewall venting

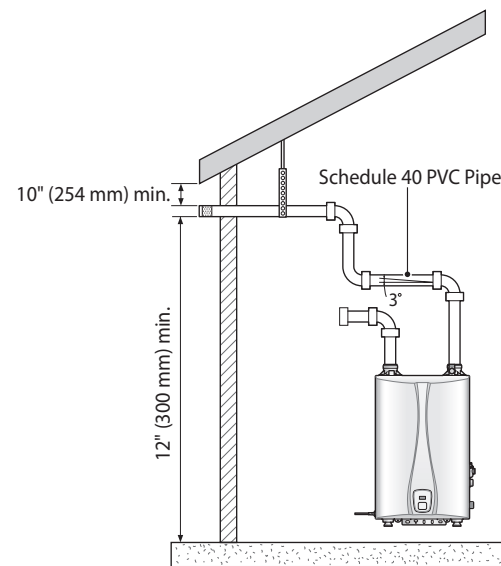

Caution

- Maintain 12" (300 mm) min. (18" (450 mm) min. for Canada) clearance above highest-anticipated snow level. Maximum of 24" (600 mm) above roof.
- Install a bird screen at the end of the intake air pipe.



Notice

Single-pipe venting requires that adequate combustion air be provided in end-use installations per NFPA 54 C.9.3.2.

Two-pipe sidewall venting

Internal view

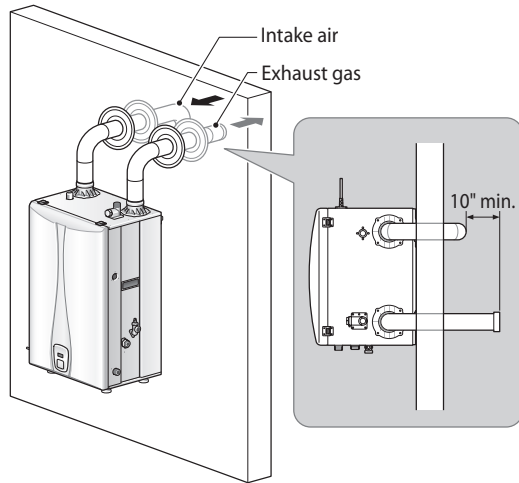

External view

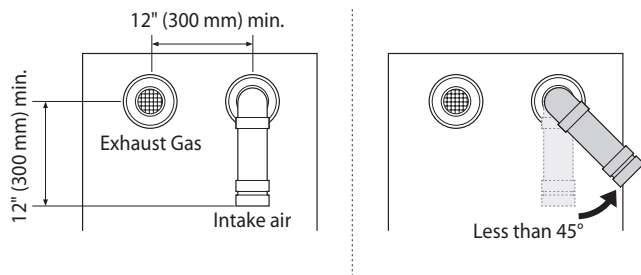

Caution

- Maintain 12" (300 mm) min. (18" (450 mm) min. for Canada) clearance above highest-anticipated snow level. Maximum of 24" (600 mm) above roof.
- Install a bird screen at the end of the intake air pipe.

Notice

It is recommended to install the intake air vent terminal as far from the exhaust gas vent terminal as possible.

Snorkel flue

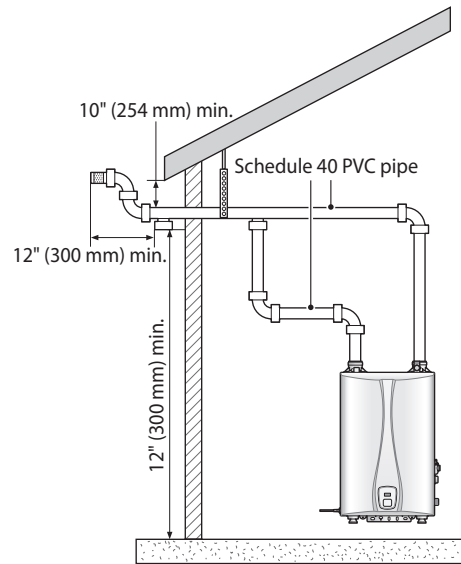

Caution

- Maintain 12" (300 mm) min. (18" (450 mm) min. for Canada) clearance above highest-anticipated snow level. Maximum of 24" (600 mm) above roof.
- Install a bird screen at the end of the intake air pipe.

Non-concentric sidewall venting

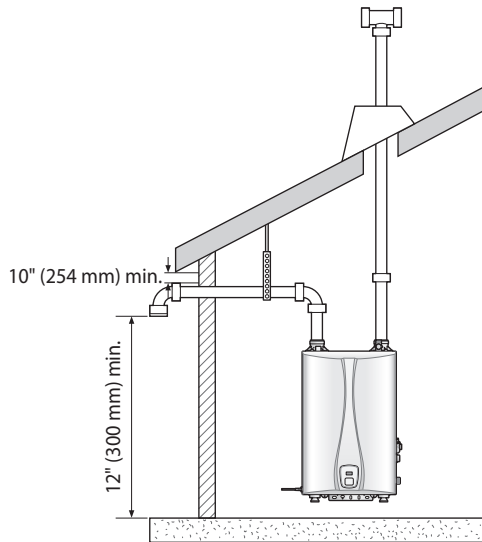

- Maintain 12" (300 mm) min. (18" (450 mm) min. for Canada) clearance above highest-anticipated snow level. Maximum of 24" (600 mm) above roof.
- Install a bird screen at the end of the intake air pipe.

Notice

Air is drawn from a different location at a minimum of 12" (300mm) from the exhaust termination. Try to minimize the length of the intake air pipe with this venting.

Two-pipe vertical venting

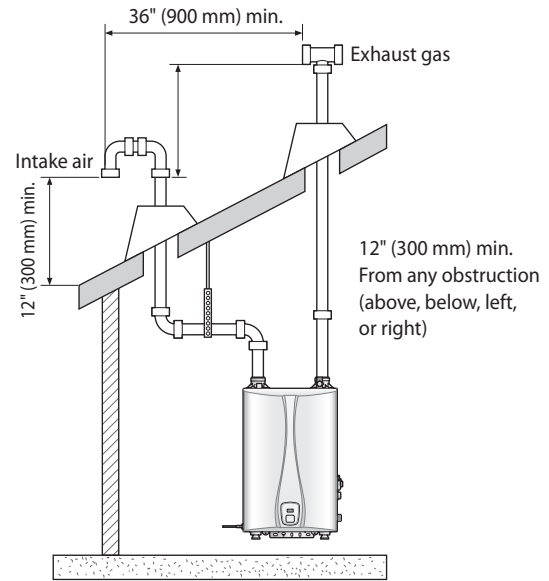

- Maintain 12" (300 mm) min. (18" (450 mm) min. for Canada) clearance above highest-anticipated snow level. Maximum of 24" (600 mm) above roof.
- Install a bird screen at the end of the intake air pipe.

Notice

Intake and exhaust pipes do not have to terminate in the same area.

Concentric sidewall venting

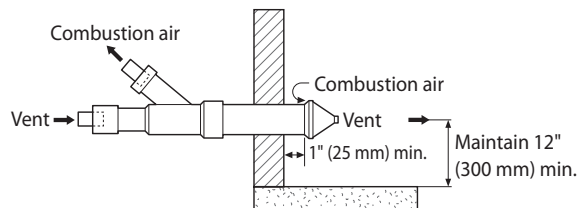

- Maintain 12" (300 mm) min. (18" (450 mm) min. for Canada) clearance above highest-anticipated snow level. Maximum of 24" (600 mm) above roof.

Concentric roof venting

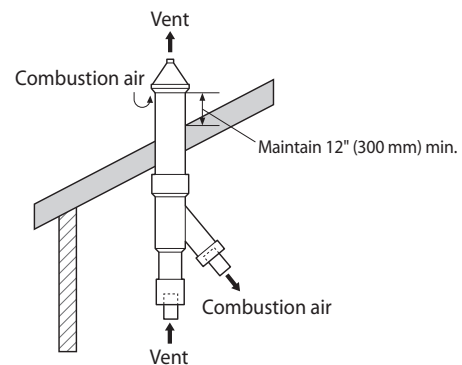

- Maintain 12" (300 mm) min. (18" (450 mm) min. for Canada) clearance above highest-anticipated snow level. Maximum of 24" (600 mm) above roof.

Setting the DIP Switches (for Cascade System)

The water heater has a DIP switch on the main circuit board (PCB). There are two sets of DIP switches that control the cascade system of the water heater. Set the DIP switches appropriately, depending on the installation environment.

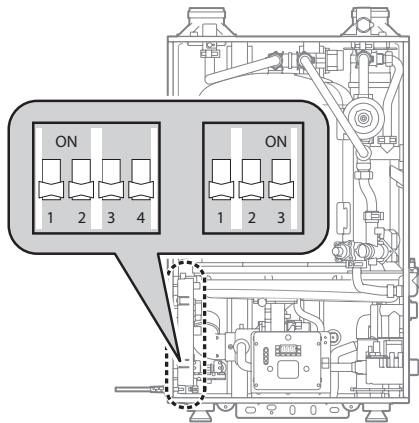

4-switch panel

Switch	Function
	Cascade operation
	Minimum heat capacity operation
	Maximum heat capacity operation

3-switch panel

Switch	Function
	One water heater is in use.
	Two water heaters are in use for the cascade system.
	Three water heaters are in use for the cascade system.
	Four water heaters are in use for the cascade system.
	Five water heaters are in use for the cascade system.
	Six water heaters are in use for the cascade system.
	Seven water heaters are in use for the cascade system.
	Eight water heaters are in use for the cascade system.

Connecting the Power Supply



Warning

Improperly connecting the power supply can result in electrical shock and electrocution. Follow all applicable electrical codes of the local authority having jurisdiction. In the absence of such requirements, follow the latest edition of the National Electrical Code (NFPA 70) in the USA or the latest edition of CSA C22.1 Canadian Electrical Code Part 1 in Canada. Connecting the power supply should be performed only by a licensed professional.

When connecting the power supply, follow these guidelines:

- Do not connect the electric supply until all plumbing and gas piping is complete and the water heater has been filled with water.
- Do not connect the water heater to a 220-240V AC power supply. Doing so will damage the water heater and void the warranty.
- All water heaters come with a factory-installed, 3-pronged (grounded) plug. The water heater can be plugged into any grounded electrical outlet nearby, as it requires only 2-4 Amps. It is not necessary to run a dedicated electrical line to the water heater.
- If local codes require the water heater to be wired directly, remove and discard the factory-installed plug. Install a power switch between the breaker and the water heater to facilitate end-user maintenance and servicing. Connect the water heater to a 110-120V AC at 60 Hz with a maximum of 5A rating electrical supply.
- The water heater must be electrically grounded. If using the power plug, ensure that the electrical outlet you connect the water heater to is properly grounded. If wiring the water heater directly to a power supply, do not attach the ground wire to either the gas or the water piping as plastic pipe or dielectric unions may prevent proper grounding.
- We recommend using a surge protector to protect the water heater from power surges.
- If there is a power failure in cold weather areas, the freeze prevention system in the water heater will not operate and may result in freezing of the heat exchanger. In cold weather areas where power failures are common, you must completely drain the water heater to prevent damage if the power is expected to be off for any extended period of time. A battery back-up (available at most computer retailers) may be used to supply hot water during periods of power outages. Damage caused by freezing is not covered under warranty.



Self-adjusting Mode



After installing the water heater you must proceed to Self-adjusting Mode before using the water heater.

In Self-adjusting Mode, the water heater calculates the load according to the installation circumstances (altitude, vent) and self adjust the heat capacity by itself.

To use the Self-adjusting Mode:

- 1 Connect the power supply.
- 2 Press the  button.
- 3 Open more than two faucets and dispense approximately 4 gallons (15 liters) of water.
- 4 Check that the  icon is turned on.



Notice

Temperature is set to 120°F (50°C) by default.

- 5 Touch the  button and increase the temperature higher than 160°F (71°C).



- 6 Touch the  button and turn off the water heater.



- 7 Touch the  button and the MODE button simultaneously for more than 5 seconds. "CAL1" appears on the digital display and start flashing.



- 9 After the heat capacity adjustment is finished, "CAL1" disappears from the digital display. Close all faucets.



- 8 "CAL 1" flashes for about 6 minutes. When "CAL1" is flashing, it means the heat capacity is adjusting.



Installation Checklist

After the water heater installation, examine the following checklist. If you are not able to answer "Yes" to all of the items in the checklist, review the appropriate sections. To troubleshoot any operational problems, refer to "Troubleshooting" in the User's Manual.

If there are additional questions or if you need assistance, contact technical support at 1-800-761-0053.

Location	Check
Is the make-up air supply free from corrosive elements and flammable vapors?	<input type="checkbox"/>
Is the water heater clear of combustible materials?	<input type="checkbox"/>
Is the gas control valve accessible for servicing?	<input type="checkbox"/>
Have you maintained the proper service and maintenance clearances?	<input type="checkbox"/>

Gas connection	Check
Have you tested all the fittings for leaks?	<input type="checkbox"/>
Does the gas supply match the gas type specified on the water heater's rating plate?	<input type="checkbox"/>
Is the gas supply pressure adequate as the gas supply pressure specified in the water heater's rating plate?	<input type="checkbox"/>
Does the installation conform with local codes or, in the absence of local codes, the National Fuel Gas Code ANSI Z223.1/NFPA 54?	<input type="checkbox"/>
Does the gas line have an inner diameter of at least 1/2"?	<input type="checkbox"/>

Water connection	Check
Is the water supply pressure sufficient (greater than 40 PSI)?	<input type="checkbox"/>
Have you verified that the cold water line and the hot water line do not intersect and have you tested for leaks?	<input type="checkbox"/>
Is the approved pressure relief valve installed properly?	<input type="checkbox"/>
Have you verified that there are no products installed which exceeds the maximum pressure specified in the water heater's rating plate?	<input type="checkbox"/>

Venting	Check
Is the distance between the exhaust vent terminal and the intake air vent terminal far enough, and more than the distance specified in the manual?	<input type="checkbox"/>
Are the air intake and exhaust connections on the flue and vent lines correctly sealed?	<input type="checkbox"/>
Have you checked venting for leaks?	<input type="checkbox"/>
Are all vent runs properly supported?	<input type="checkbox"/>
Is the vent termination properly supported?	<input type="checkbox"/>
Have you explained to the owner importance that vent termination not be blocked?	<input type="checkbox"/>
Have you run the "Self-adjusting Mode" if you installed the water heater in a location higher than 4500 ft.?	<input type="checkbox"/>

Others	Check
Is the front panel working properly?	<input type="checkbox"/>
Have you filled the condensate trap with fresh water?	<input type="checkbox"/>
Have you explained how to operate the water heater, safety guidelines, maintenance, and warranty to the owner?	<input type="checkbox"/>
Have you delivered the manuals directly?	<input type="checkbox"/>

Appendix

Gas Conversion

This water heater is configured for Natural Gas from the factory. If conversion to Propane Gas is required, the conversion kit supplied with the water heater must be used.



Danger

Inspect the packing between the gas valve and gas pipe whenever they are disassembled. The packing must be installed and must be in good condition. Failure to comply will cause a gas leak, resulting in severe personal injury or death.



Warning

This conversion kit shall be installed by a qualified service agency* in accordance with Vesta instructions and all applicable codes and requirements of the authority having jurisdiction. The information in these instructions must be followed to minimize the risk of fire or explosion and/or to prevent property damage, personal injury or death. The qualified service agency is responsible for the proper installation of this kit. The installation is not proper and complete until the operation of the converted appliance is checked as specified in the manufacturer's instructions supplied with the kit.

* A qualified service agency is any individual, firm, corporation or company which either in person or through a representative is engaged in and is responsible for the connection, utilization, repair or servicing of gas utilization equipment or accessories; who is experienced in such work, familiar with all precautions required, and has complied with all of the requirements of the authority having jurisdiction.

In Canada: The conversion shall be carried out in accordance with the requirements of the provincial authorities having jurisdiction and in accordance with the requirements of the CAN B149.1 and CAN1 B149.2 Installation Codes.

To convert the gas:

- 1 Turn off the manual gas shut off valve and the water supply to the water heater.

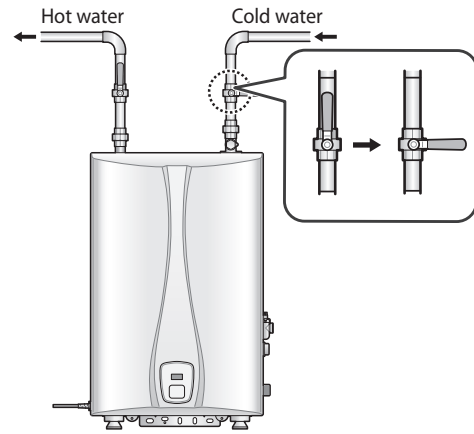
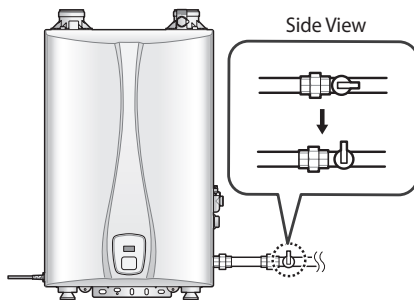

- 2 Remove the water heater front cover by loosening the 2 Phillips screws securing it to the case.

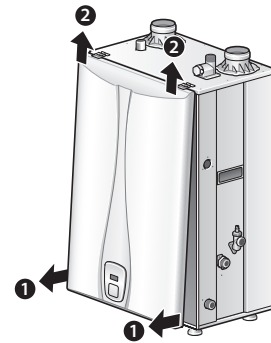
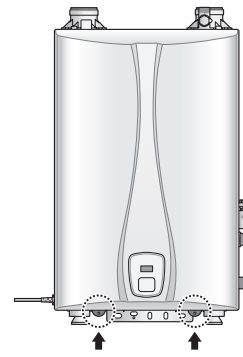

- Once the front cover is removed, place it in a safe location to prevent accidental damage. With the internal components exposed, locate the gas inlet pipe and the gas valve near the bottom side of the water heater.

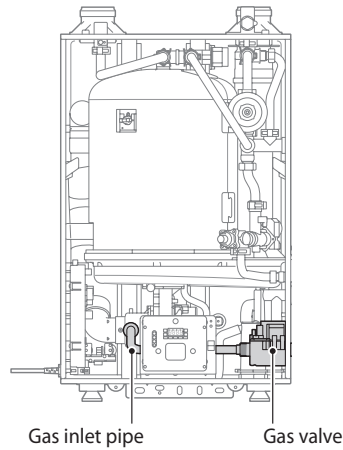

- Loosen the nut connecting the gas inlet pipe to the gas valve.

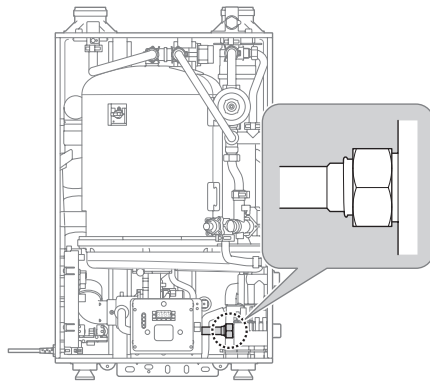

- Once the gas inlet pipe is detached from the gas valve, replace the old orifice piece and the packing with the new part for use with LP gas. Ensure that the orifice is properly seated inside the port.

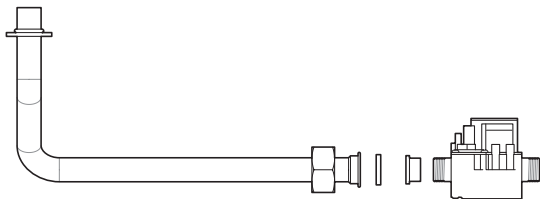

- Replace the gas inlet pipe to its original position and tighten the nut to secure the gas connections.

Cascade System

When installing a cascade system, carefully consider the design of the system and the features of the installation location. Follow all local codes and regulations, as well as all guidelines for installing the water heater. The following sections describe additional considerations that are specific to installing a cascade system. Read the following sections carefully before designing or installing the system.

Piping sizes

When plumbing a cascade system, consider the following pipe diameters and flow rates (note that flow rates above 6.6 ft/s may cause pipe erosion). These specifications may vary depending on installation conditions.

Qty	$\Delta T=54^{\circ}F$ Flow Rate (GPM)	Water Velocity (ft/s)	Pipe Diameter (mm/in)	
1	6.82	4.53	20A	3/4"
2	13.64	5.32	25A	1"
3	20.46	5.25	30A	1 1/4"
4	27.28	4.94	40A	1 1/2"
5	34.10	6.19	40A	1 1/2"
6	40.92	4.26	50A	2"
7	47.74	4.97	50A	2"
8	54.56	5.69	50A	2"

Water supply

Several options are available for plumbing a cascading system of water heaters. The options shown here are examples only. The setup you choose will vary depending on the installation location, local building codes, and other factors. Follow all applicable regulations when installing a cascade system.

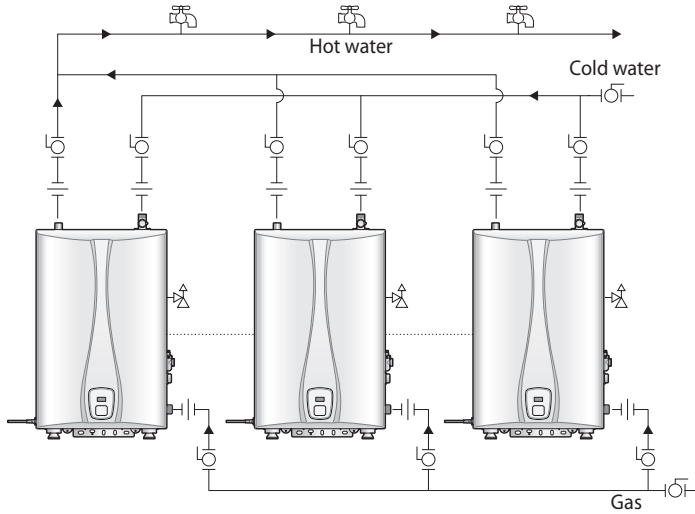

- | | |
|-----------------------|------------------|
| Ball valve | Circulation pump |
| Union | Check valve |
| Pressure relief valve | Faucet |
| Expansion tank | |

Notice

The recommended minimum recirculation flow rate for each water heater is 2 GPM.

Communication cables



To avoid electric shock, turn off the water heater while connecting the wires.

Up to 8 water heaters can be connected with cascade communication cables.

To connect the cascade communication cables:

- 1 Connect the cascade communication cable connector to the connector socket on the PCB assembly.

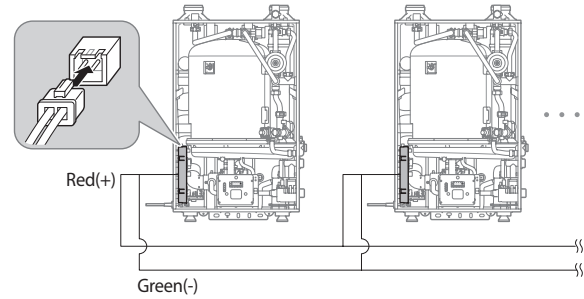

- 2 Remove the plastic insulation from opposite ends of the cascade communication cable.

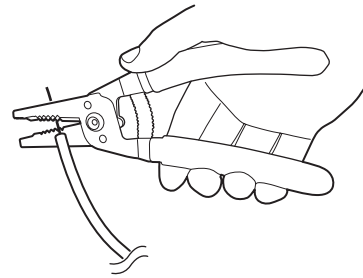

- 3 Connect the cascade communication cables by matching the colors (red, green).

Notice

Set the DIP switches after connecting the cascade communication cables. For more information about setting the DIP switches, refer to "Setting the DIP Switches (for Cascade System)" on page 30.

Wiring Diagram

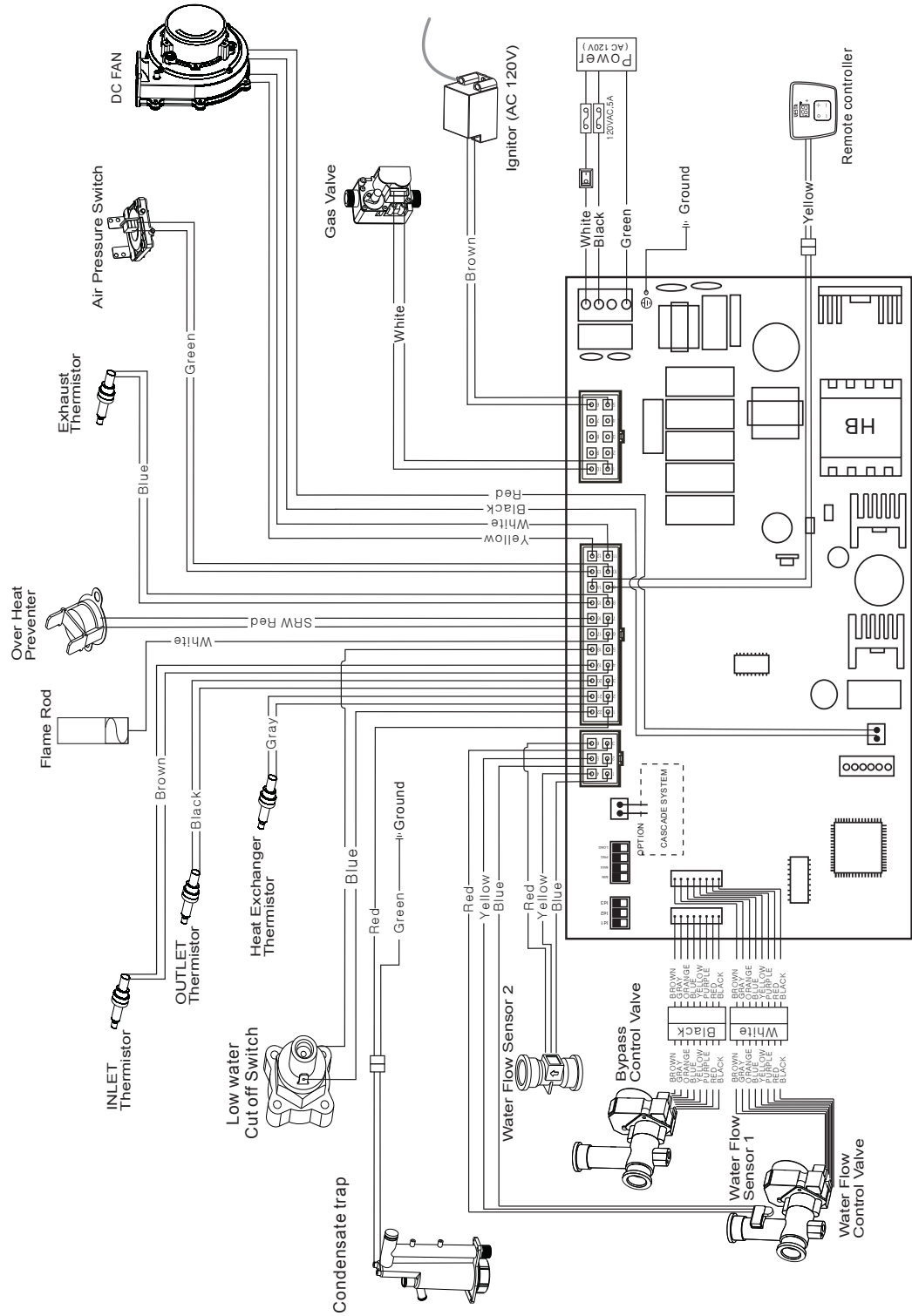

Component Assembly Diagrams and Parts Lists

■ Case Parts

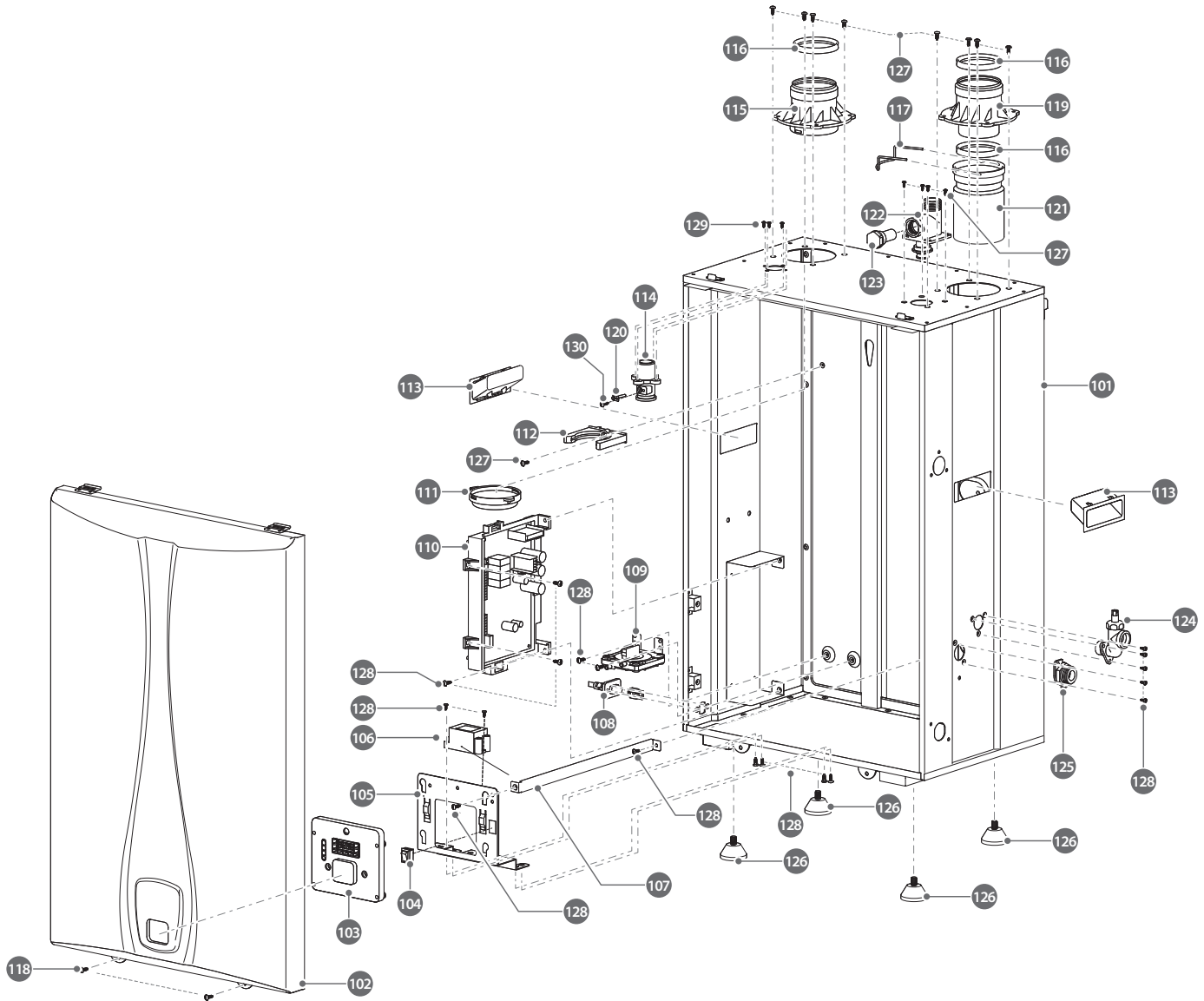

NO	Part NO	Part Name
101	2070651	Chassis Assembly
102	2010590	Case Assembly
103	2081072	R/C Assembly
104	2080736	Power Switch
105	3011565	R/C Bracket
106	2080979	igniter+Wire
107	3011615	R/C Support Bracket
108	3130755	Power Supply Wire
109	2100353	Air Pressure Switch
110	2081086	PCB Assembly
111	3040604	Air Intake Filter
112	3080290	Saddle
113	3040576	Handle
114	3030227	Outlet Nipple
115	3040602	Air Intake Connector
116	3080235	Flue Packing
117	3120139	Reducer Pin
118	3100044	M4x12 Screw
119	3040603	Flue Connector
120	3130750	Hot Water Outlet Temperature Sensor
121	3040687	Flue Connector Reducer
122	3030246	Inlet Nipple
123	3120136	Inlet Nipple Filter
124	2060356	Drain Valve
125	3040579	Trap Nut
126	3080232	Rubber Foot
127	3100132	Ø4x12 Tapping Screw
128	3100189	Ø4x10 Tapping Screw
129	3100183	M5x9 Screw
130	3100174	M4x6 Screw

Flue Parts

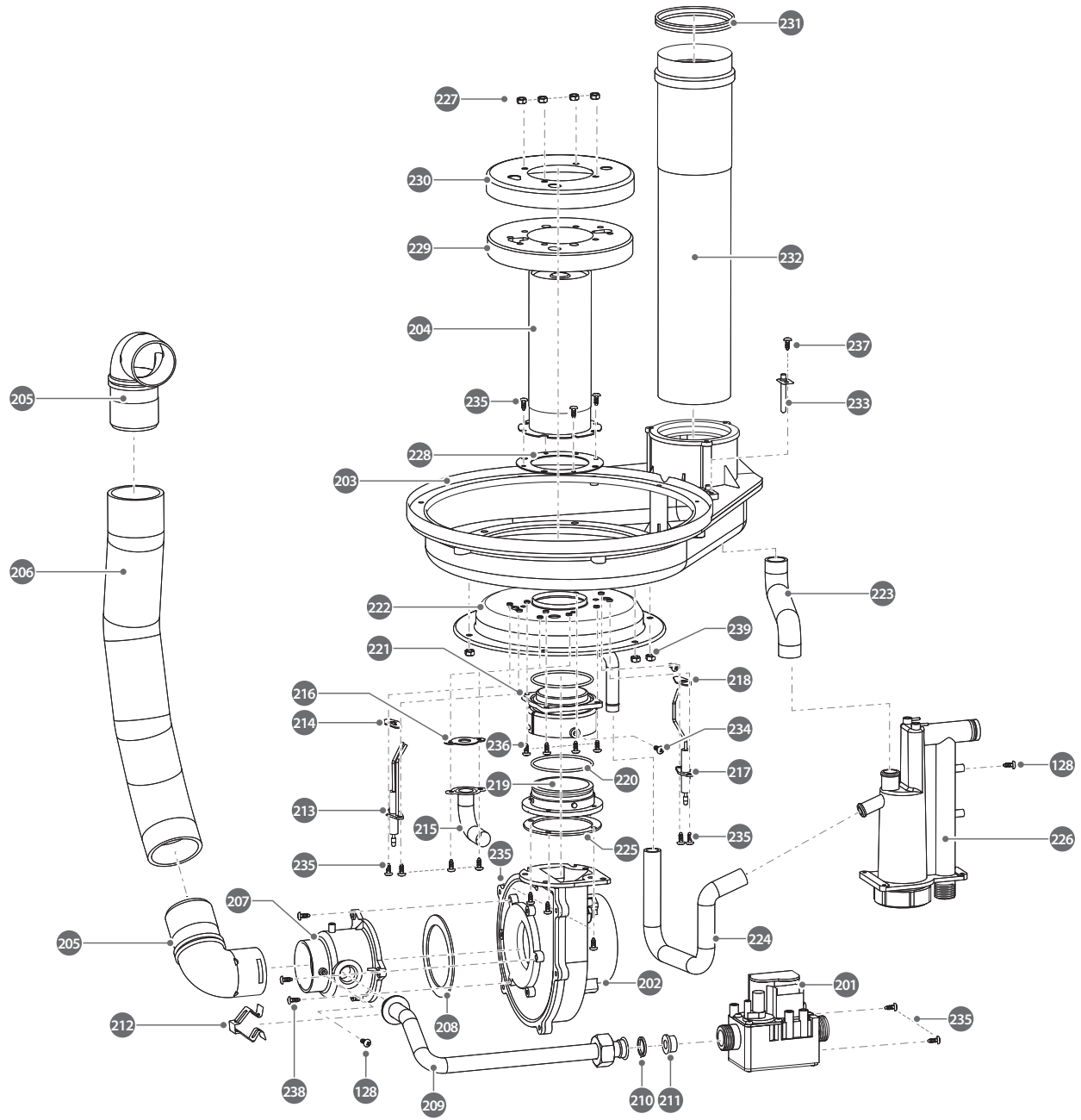

NO	Part NO	Part Name
201	2030291	Gas Valve
202	2100336	Turbo Fan
203	2100354	Duct Assembly
204	2020408	Burner
205	3040590	Air Intake Elbow
206	3160224	Air Intake Hose
207	3040570	Air Box
208	3090372	Fan Gasket
209	2091035	Gas Pipe
210	3080176	3/4" Packing
211	3011653	LNG Orifice
	3011651	LPG Orifice
212	3011010	Joint Clip(16A)
213	2020406	Spark Plug
214	3090363	Spark Plug Gasket
215	2091017	Flam View Pipe
216	3090362	Flam View Pipe Gasket
217	2020407	Flame Rod
218	3090362	Flame Rod Gasket
219	3050101	Fan Connector
220	3080220	Fan Connector O-Ring
221	3050100	Fan Adapter
222	3011393	Burner Plate
223	3080223	Condensate Hose
224	2060375	Condensate Silicone Hose
225	3090373	Fan Connector Gasket
226	2060339	Condensate Trap Assembly
227	3100176	M4 Nut
228	3090361	Burner Gasket
229	3090341	Ceramics Board
230	3011577	Ceramics Board Cover
231	3080221	P75 O-Ring
232	2100326	Exhaust Stainless Pipe
233	3130751	Exhaust Temperature Sensor
234	3100146	M5x10 Screw
235	3100184	M4x8 Screw
236	3100175	M4x30 Screw
237	3100033	Ø4x8 Tapping Screw
238	3100196	M4x12 Screw
239	3100177	M5 Nut

Water Parts

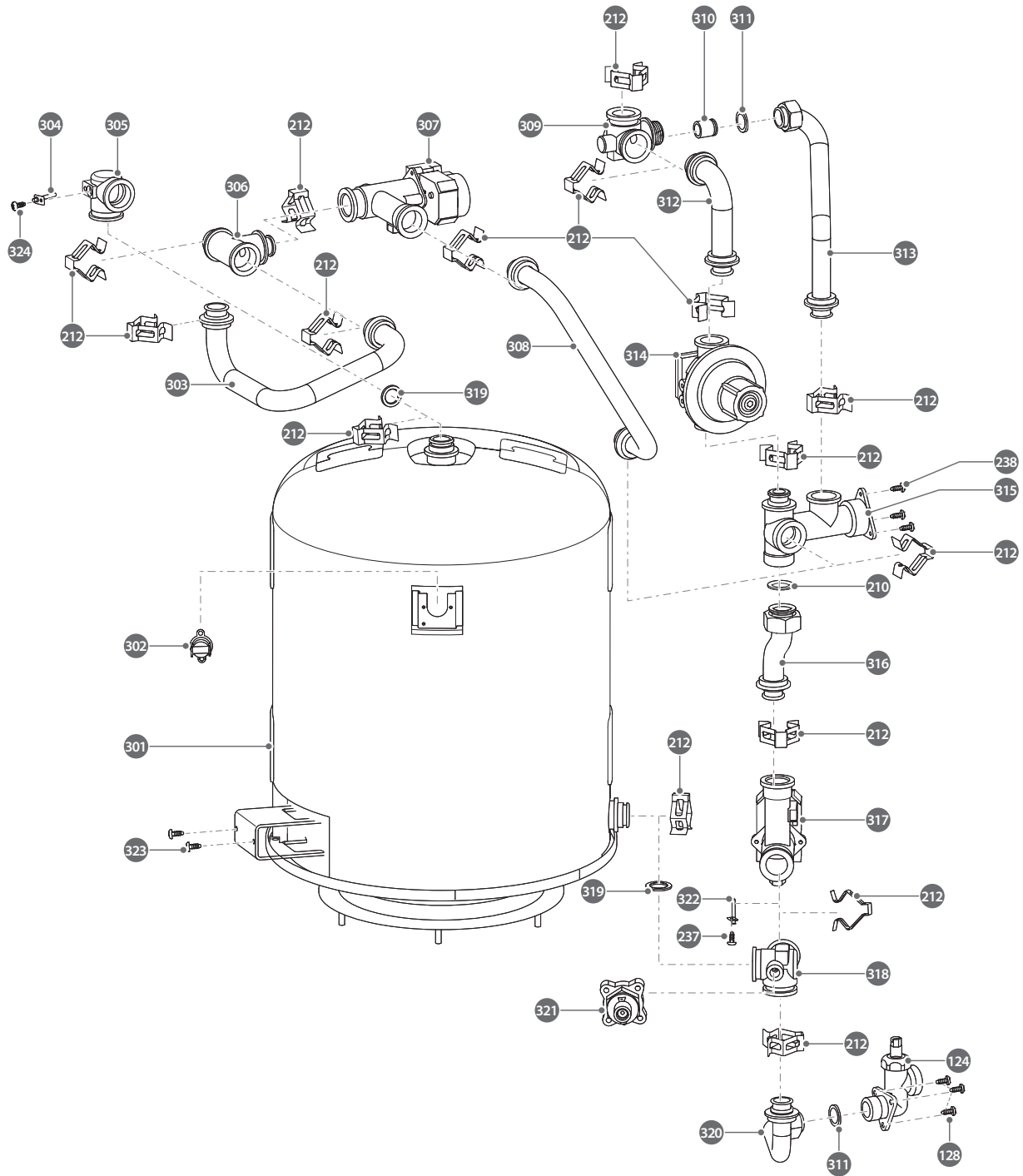

NO	Part NO	Part Name
301	2120081	Heat Exchanger Tank
302	2081084	Overheat Preventer
303	2091092	Outlet Pipe
304	3130749	Tank Outlet temperature Sensor
305	3030228	Tank T
306	3030226	Mixing T
307	2060384	Mixing Valve
308	2091016	Mixing Pipe
309	3030251	Clod Water Inlet 3Way Nipple
310	2060344	Check Valve
311	3080043	1/2" Packing
312	2091120	Water Inlet Elbow Pipe
313	2091121	By-Pass Pipe
314	2060357	Surge Pressure Regulation Valve
315	3030253	Cold Water Block
316	2091093	Flow Control Valve Inlet Pipe
317	2060262	Flow Control Valve
318	3030252	Tank Inlet Nipple
319	3080277	P18 O-Ring
320	2091036	Drain Pipe
321	2060338	Low Water Cut Off Switch
322	3130380A	Cold Water Temperature Sensor
323	3100194	M5x12 Screw

Memo



Memo





SMART & COMFORT

Address

2711 LBJ Fwy Suite#320, Farmers branch, TX, 75234

For Technical Support

1-800-761-0053

www.vestahws.com

Ver. 1.0